



baglioni
pressure solutions

www.baglionspa.com

Vessels



Company



Baglioni Headquarters
Via Dante Alighieri, 8
28060 San Pietro
Mosezzo (NO) Italy
Tel. +39 0321485211

The companies of **Baglioni Spa** manufacture carbon- and stainless-steel pressure equipment used for storage and processing in the compressed-air, Oil&Gas, cryogenics, air-treatment and oil/sludge filtering sectors.

Baglioni Group includes eight companies located in EUROPE, USA and CHINA.

Sales Contact

sales@baglionispa.com

Engineering Contact

tecnico@baglionispa.com



ASTRA ENERGY OIL & GAS
Via Meucci
28066 Galliate (Novara) Italy
Tel. +39 0321 485611



ASTRA SERBATOI
Strada per Villata, 2
28060 CASALVOLONE (Novara) Italy
Tel. +39 0161 315494

ASTRA SPECIAL PRESSURE EQUIPMENT
Viale Leopardi, 27
28060 SAN PIETRO MOSEZZO (Novara) Italy
Tel. +39 0321 485611



ASTRA SERBATOI
Strada Statale 16, Km 977+400
73022 CORIGLIANO D'OTRANTO (Lecce) Italy
Tel. +39 0836 471239



CSC SERBATOI
Strada Cacciolo, 34
15030 TERRUGGIA (Alessandria) Italy
Tel. +39 0142 403055

CSC LOGISTICA
Strada Valmacca, 40
15040 TICINETO (Alessandria) Italy
Tel. +39 0142 411688



MPV MORGANTON PRESSURE VESSELS SPECIAL PRESSURE EQUIPMENT
1 Alfredo Baglioni Drive
MARION NC 28752 USA
Tel. +1 (828) 6523704

MPV MORGANTON PRESSURE VESSELS VESSELS
2440 HWY 31
Bay Minette AL 36507



AIR COM SHANGHAI PRESSURE CONTAINER CO. LTD
Da Mai Wan Industrial Zone No. 28 Hangqi Rd.
Hangtou Nanhui - Shanghai, 201316, P.R.
China - Tel. +86 (0)21 68220793



EURE SHANGHAI MACHINERY EQUIPMENT CO. LTD
Da Mai Wan Industrial Zone No. 30 Hangqi Rd.
Hangtou Nanhui - Shanghai, 201316, P.R.
China - Tel. +86 (0)21 58225183

4
5
6
7
8
9
10
11
12
13
14
15
16
17
18
19
20
21
22
23
24
25
26
27
28
29
30
31

CERTIFICATIONS

FINISHING

-10°C AIR vessels

SMALL-SIZE VERTICAL AIR VESSELS

SMALL-SIZE HORIZONTAL AIR VESSELS

PAINTED HORIZONTAL AIR VESSELS

GALVANIZED AND ALM-PAINTED HORIZONTAL AIR VESSELS

11-12-16 BAR -10°C PAINTED VERTICAL AIR VESSELS

11-12-16 BAR -10°C GALVANIZED VERTICAL AIR VESSELS

11-12-16 BAR -10°C VERTICAL AIR VESSELS WITH INTERNAL ALM PAINT

VACUUM VERTICAL AIR VESSELS

-20°C AIR vessels

11-12-16 BAR -20°C PAINTED VERTICAL AIR VESSELS

-20°C GALVANIZED / ALM-PAINTED / OXYGEN VERTICAL AIR VESSELS

-20°C OVERSIZE PAINTED VERTICAL AIR VESSELS

-20°C OVERSIZE GALVANIZED / ALM-PAINTED / OXYGEN VERTICAL AIR VESSELS

-20°C OVERSIZE PAINTED / ALM-PAINTED HORIZONTAL AIR VESSELS

21 BAR -20°C PAINTED / ALM-PAINTED VERTICAL AIR VESSELS

32 BAR -20°C PAINTED / ALM-PAINTED VERTICAL AIR VESSELS

42 BAR -20°C PAINTED / ALM-PAINTED VERTICAL AIR VESSELS

Other vessels

GALVANIZED VERTICAL VESSELS FOR PRESSURIZED WATER (AUTOCLAVE)

GALVANIZED HORIZONTAL VESSELS FOR PRESSURIZED WATER (AUTOCLAVE)

STAINLESS-STEEL VERTICAL VESSELS

STAINLESS-STEEL HORIZONTAL VESSELS

ASME VESSELS

FLANGED CONNECTIONS AND NON-MANDATORY INSPECTION OPENINGS

DECLARATION OF CONFORMITY

INSTRUCTIONS FOR USE AND MAINTENANCE

ACCESSORIES

SPECIAL PROJECTS

Certifications

Our products are designed and manufactured in compliance with the applicable EU Directives or according to the major international standards, such as:

- ▲ SPVD 2014/29/UE Directive (ex 2009/105/EC) *Simple Pressure Vessels Directive*
- ▲ PED 2014/68/UE Directive (ex 97/23/EC) *Pressure Equipment Directive*
- ▲ ASME Sect. VIII Div. 1 / Div. 2
- ▲ National Board Registration
- ▲ Canadian Registration Number (CRN)
- ▲ Australian Standard AS1210
- ▲ MOM Singapore Regulation
- ▲ DOSH Malaysia Regulation
- ▲ Visto Consolare
 - Tunisia
 - Morocco
- ▲ Manufacture License of Special Equipment People's Republic of China D1/D2 - A1/A2
- ▲ MHLW Japan Regulation
- ▲ Israelian Standard Regulation
- ▲ Croazia Registration
- ▲ Marine Registration
 - ABS American Bureau of Shipping
 - DNV Det Norske Veritas
 - B.V. Bureau Veritas
 - LRS Lloyd's Register of Naval Ship
 - RINA Services
 - GL Germanischer Lloyd
 - NK Nippon Kaiji Kyokai
 - CCS China Classification Society
 - RMRS Russian Maritime Register of Shipping
 - KR Korean Register of Shipping
- ▲ EAC TRCU032 RUSSIA



FINISHING



PAINTING: external surface treatment performed on all standard vessels.

After an accurate surface preparation through chemical wash-down or sandblasting, the product is transferred to dedicated booths where powder paint is sprayed by means of electrostatic or triboelectric spray guns. The processed product is then baked in curing ovens.



HOT-DIP GALVANIZATION: internal and external treatment for carbon steel vessels.

Hot-dip galvanizing is the main method used to protect steel against weather conditions and is performed by dipping vessels in a molten zinc bath. During this metallurgical process, the surface composition changes into an intercrystalline zinc-steel alloy that forms an extremely resistant, long-lasting anti-corrosion coating. The thickness of the protection depends on material type, dipping time and zinc bath temperature.



ALM PAINTING: this treatment is specific for tank interiors and is performed by applying special protective paints that ensure high resistance to corrosive agents over time.

Raw vessels first undergo chemical washing and pickling and are then sprayed with thermosetting epoxy resin before completing the process with the final baking stage in the oven. The ALM treatment is certified pursuant to Ministerial Decree dated 21 March 1973 and subsequent amendment dated 6 April 2004, governing the hygiene of food-grade containers containing substances for personal use.



PICKLING AND PASSIVATION: Internal and external treatment for stainless steel vessels.

Pickling is essential to remove the oxide particles produced during the various processing stages. There are two types of pickling systems: mechanical and chemical. The former is performed with silica sand or stainless-steel brushes, the latter by dipping the item into an acid solution. The subsequent passivation dissolves and removes any contaminants from the surface, thus recreating the protective layer.

SURFACE ELECTROPOLISHING TREATMENT:

This surface treatment electrolytically removes all metal particles in order to reduce roughness. This process is essential when corrosion-resistance and cleanliness requirements are particularly strict (e.g., for pharmaceutical, chemical, biochemical and food products).

FOOD-GRADE AND PHARMACEUTICAL TREATMENT:

This special treatment is performed after pickling and passivation, as required for food and pharmaceutical processing in compliance with ASTM A380 regulation.



RAL 1004
SMOOTH FINISH



RAL 3000
SMOOTH/TEXTURED FINISH



RAL 5002
SMOOTH FINISH



RAL 5005
TEXTURED FINISH



RAL 5010
SMOOTH FINISH



RAL 5015
SMOOTH/TEXTURED FINISH



RAL 7011
TEXTURED FINISH



RAL 7016
SMOOTH/TEXTURED FINISH



RAL 7021
SMOOTH/TEXTURED FINISH



RAL 7024
TEXTURED FINISH



RAL 7035
TEXTURED FINISH



RAL 7036
TEXTURED FINISH



RAL 7040
TEXTURED FINISH



RAL 7042
TEXTURED FINISH



RAL 7043
SMOOTH FINISH



RAL 9002
TEXTURED FINISH

SMALL-SIZE VERTICAL AIR VESSELS



DIRECTIVE

2014/29/UE

OPERATING PRESSURE

11/16 BAR

OPERATING TEMPERATURE

-10 +100°C

RAL5015

GALVANIZED

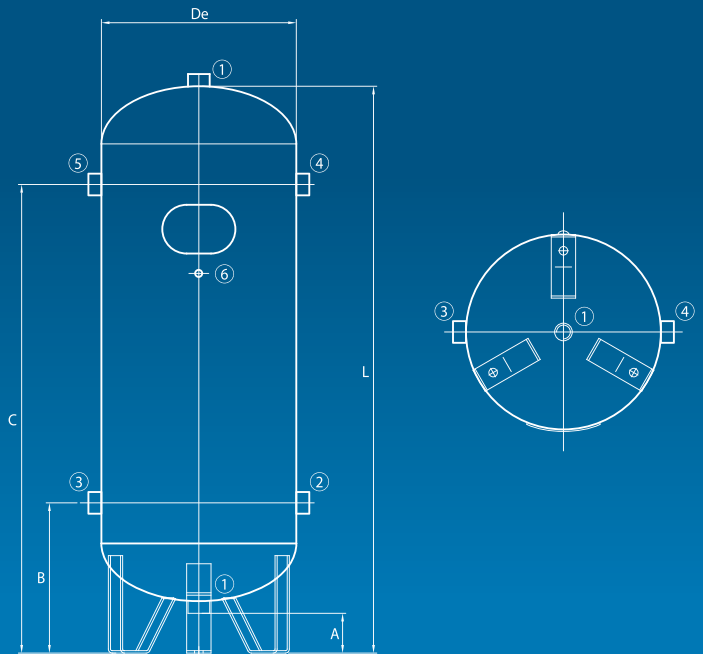

- MATERIAL: CARBON STEEL
- FLUID CONTENT: COMPRESSED AIR / NITROGEN (GROUP 2)
- FINISHING: EXTERNAL RAL 5015 BLUE PAINT (STANDARD) AND INTERNAL AND EXTERNAL HOT-DIP GALVANIZATION
- UPON REQUEST: 1" COUPLINGS ON HEADS



CODE	Directive	Capacity	Operating pressure	De	A	B	C	L	1	2	3	4	5	6	Weight
RAL 5015		Lt	Bar	mm	mm	mm	mm	mm	inch	inch	inch	inch	inch	inch	Kg
VEC01295	2014/29/UE	24	11	240	64	185	535	656	1/2"	=	1/2"	1/2"	=	3/8"	10
VEC01296	2014/29/UE	50	11	305	145	297	777	929	1/2"	1/2"	=	=	1/2"	3/8"	19
VEC00875	2014/29/UE	50	15	305	145	297	777	929	1/2"	1/2"	=	=	1/2"	3/8"	23
GALVANIZED		Lt	Bar	mm	mm	mm	mm	mm	inch	inch	inch	inch	inch	inch	Kg
VEC02301	2014/29/UE	24	11	240	64	185	535	656	1"	=	1/2"	1/2"	=	3/8"	11
VEC01736	2014/29/UE	50	11	305	145	297	777	929	1"	1/2"	=	=	1/2"	3/8"	20

SMALL-SIZE HORIZONTAL AIR VESSELS

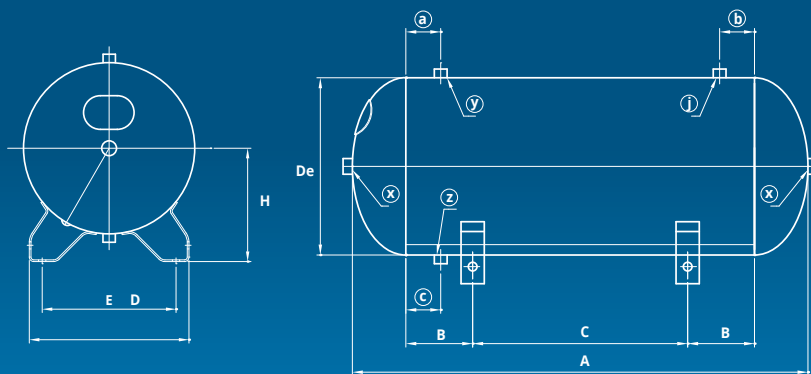

- MATERIAL: CARBON STEEL
- FLUID CONTENT: COMPRESSED AIR / NITROGEN (GROUP 2)
- FINISHING: EXTERNAL RAL 5015 BLUE PAINT (STANDARD) AND INTERNAL AND EXTERNAL HOT-DIP GALVANIZATION
- UPON REQUEST: 1" COUPLINGS ON HEADS

DIRECTIVE	2014/29/UE
OPERATING PRESSURE	11/16 BAR
OPERATING TEMPERATURE	-10 +100°C

HORIZONTAL VESSELS WITH FIXED FEET

CODE	Directive	Capacity	Operating pressure	De	A	B	C	D	E	H	a	b	c	x	y	j	z	Weight	
		Lt	Bar	mm	mm	mm	mm	mm	mm	mm	mm	mm	mm	inch	inch	inch	inch	Kg	
RAL 5015																			
VEC01294	2014/29/UE	5	11	150	370	37,5	200	140	191	120	-	-	137,5	1/2"	-	-	1/4"	6,5	
VEC01249	2014/29/UE	10	11	169	506	85	240	172	205	115	-	60	50	1/2"	-	3/8"	3/8"	8	
VEC01237	2014/29/UE	15	11	196	522	85	240	172	205	135	-	60	50	1/2"	-	3/8"	3/8"	9	
VEC01250	2014/29/UE	24	11	240	592	95	260	180	235	165	-	60	50	1/2"	-	3/8"	3/8"	10	
VEC01251	2014/29/UE	50	11	305	784	90	400	236	285	203	60	60	60	1/2"	1/2"	1/2"	3/8"	19	
VEC01715	2014/29/UE	24	16	240	592	95	260	180	235	165	-	60	50	1/2"	-	3/8"	3/8"	13	
VEC02313	2014/29/UE	50	15	305	784	90	400	236	285	203	60	60	60	1/2"	1/2"	1/2"	3/8"	23	
GALVANIZED																			
VEC03220	2014/29/UE	10	11	169	506	85	240	172	205	115	-	60	50	1"	-	3/8"	1/4"	8	
VEC04702	2014/29/UE	15	11	196	522	85	240	172	205	135	-	60	50	1"	-	3/8"	3/8"	9	
VEC03019	2014/29/UE	24	11	240	592	95	260	180	235	165	-	60	50	1"	-	3/8"	3/8"	10	
VEC02779	2014/29/UE	50	11	305	784	90	400	236	285	203	60	60	60	1"	1/2"	3/8"	3/8"	19	

PAINTED HORIZONTAL AIR VESSELS

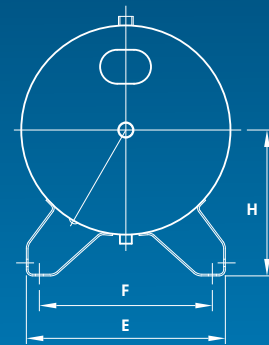
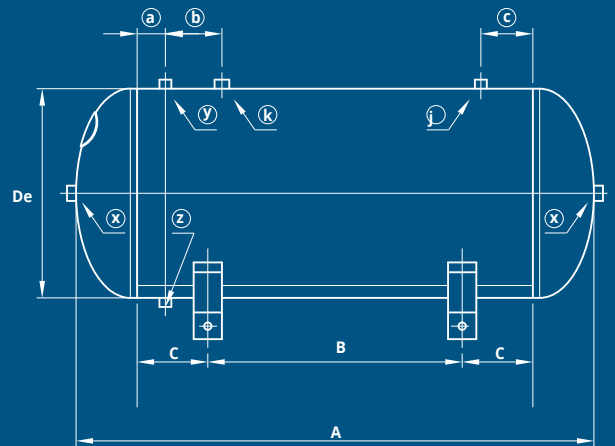
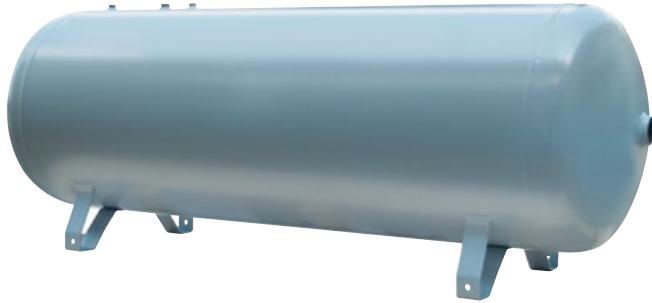

DIRECTIVE	2014/29/UE	2014/68/UE (PED)
OPERATING PRESSURE	11/16 BAR	12/16 BAR
OPERATING TEMPERATURE	-10 +100°C	-10 +50°C

- MATERIAL: CARBON STEEL
- FLUID CONTENT: COMPRESSED AIR / NITROGEN (GROUP 2)
- FINISHING: EXTERNAL RAL 5015 BLUE PAINT (STANDARD)

CODE	Directive	Capacity	Operating Pressure	De	A	B	C	E	F	H	a	b	c	x	y	k	j	z	Weight
RAL 5015		Lt	Bar	mm	mm	mm	mm	mm	mm	mm	mm	mm	mm	inch	inch	inch	inch	inch	Kg
VEC01095	2014/29/UE	100	11	370	1016	550	125	352	306	258	45	80	45	2"	3/8"	1/2"	3/8"	3/8"	29
VEC02139	2014/29/UE	150	11	396	1240	650	175	368	322	271	50	130	50	2"	3/8"	1/2"	3/8"	3/8"	44
VEC01732	2014/29/UE	200	11	446	1364	750	175	440	385	288	50	150	50	2"	3/8"	1/2"	1/2"	3/8"	55
VEC01733	2014/29/UE	270	11	500	1458	800	175	455	402	315	50	130	50	2"	3/8"	1"	1/2"	3/8"	67
VEC00728	2014/29/UE	500	11	600	1858	1204	148	530	470	396	60	155	60	2"	3/8"	1"	1/2"	3/8"	130
VEC00873	2014/29/UE	720	11	750	1850	1000	200	580	470	490	60	155	60	2"	3/8"	1"	1/2"	3/8"	178
VEC00707	2014/29/UE	900	11	800	1960	1014	243	605	490	500	60	155	60	2"	3/4"	1"	1/2"	1/2"	194
VEC00515	2014/68/UE (PED)	1000	12	800	2158	1014	343	605	490	500	100	155	60	2"	3/4"	1"	1/2"	1/2"	210
VEC00739	2014/68/UE (PED)	1500	12	1000	2135	900	300	691	575	608	200	200	-	2"	1/2"	1/2"	-	1/2"	325
VEC00680	2014/68/UE (PED)	2000	12	1100	2252	950	200	800	685	652	200	215	-	2"	1/2"	1/2"	-	1/2"	394
VEC00534	2014/68/UE (PED)	3000	12	1200	2850	1265	227	820	710	698	1230	200	-	2"	1/2"	1/2"	-	1/2"	605
VEC02257	2014/29/UE	270	16	500	1484	800	175	455	402	315	50	130	50	2"	3/8"	1"	1/2"	3/8"	104
VEC01113	2014/29/UE	500	16	600	1858	1204	148	530	470	396	60	155	60	2"	3/8"	1"	1/2"	3/8"	163
VEC00520	2014/68/UE (PED)	1000	16	800	2158	1014	343	605	490	500	100	155	60	2"	3/4"	1"	1/2"	1/2"	253
VEC00531	2014/68/UE (PED)	2000	16	1000	2570	1350	300	691	575	608	220	300	-	2"	1/2"	1/2"	-	1/2"	395
VEC02912	2014/68/UE (PED)	3000	16	1200	2850	1265	227	820	710	698	1230	200	-	2"	1/2"	1/2"	-	1/2"	640

GALVANIZED AND ALM-PAINTED HORIZONTAL AIR VESSELS

DIRECTIVE	2014/29/UE	2014/68/UE (PED)
OPERATING PRESSURE	11/16 BAR	12/16 BAR
OPERATING TEMPERATURE	-10 +100°C	-10 +50°C

- MATERIAL: CARBON STEEL
- FLUID CONTENTENT: COMPRESSED AIR/NITROGEN (GROUP 2)
- GALVANIZED FINISHING:
INTERNAL AND EXTERNALHOT-DIP GALVANIZATION
- ALM FINISHING:
EXTERNAL RAL5015 BLUE PAINT(STANDARD) AND INTERNAL RAL5005 CORROSION-RESISTANT ALM PAINT



CODE	Directive	Capacity	Operating Pressure	De	A	B	C	E	F	H	a	b	c	x	y	k	j	z	Weight
GALVANIZED		Lt	Bar	mm	mm	mm	mm	mm	mm	mm	mm	mm	mm	inch	inch	inch	inch	inch	Kg
VEC01735	2014/29/UE	270	11	500	1458	800	175	455	402	315	50	130	50	2"	3/8"	1"	1/2"	3/8"	70
VEC00874	2014/29/UE	500	11	600	1858	1204	148	530	470	396	60	155	60	2"	3/8"	1"	1/2"	3/8"	134
VEC02069	2014/29/UE	720	11	750	1850	970	215	570	460	495	60	155	60	2"	3/8"	1"	1/2"	3/8"	181
VEC02277	2014/68/UE (PED)	1000	12	800	2158	1014	343	605	490	500	100	155	60	2"	3/4"	1"	1/2"	1/2"	215
VEC00690	2014/68/UE (PED)	2000	12	1100	2252	1100	275	800	685	652	200	215	-	2"	1/2"	1/2"	-	1/2"	398
VEC02202	2014/68/UE (PED)	3000	12	1200	2850	1265	227	820	710	698	1230	200	-	2"	1/2"	1/2"	-	1/2"	609

CODE	Directive	Capacity	Operating Pressure	De	A	B	C	E	F	H	a	b	c	x	y	k	j	z	Weight
ALM		Lt	Bar	mm	mm	mm	mm	mm	mm	mm	mm	mm	mm	inch	inch	inch	inch	inch	Kg
VEC02317	2014/29/UE	270	11	500	1458	800	175	455	402	315	50	130	50	2"	3/8"	1"	1/2"	3/8"	67
VEC02127	2014/29/UE	500	11	600	1858	1204	148	530	470	396	60	155	60	2"	3/8"	1"	1/2"	3/8"	130
VEC02286	2014/29/UE	720	11	750	1850	970	215	570	460	495	60	155	60	2"	3/8"	1"	1/2"	3/8"	178
VEC02285	2014/68/UE (PED)	1000	12	800	2158	1014	343	605	490	500	100	155	60	2"	3/4"	1"	1/2"	1/2"	210
VEC02100	2014/68/UE (PED)	2000	12	1100	2252	1100	275	800	685	652	200	215	-	2"	1/2"	1/2"	-	1/2"	394
VEC02284	2014/68/UE (PED)	3000	12	1200	2850	1265	227	820	710	698	1230	200	-	2"	1/2"	1/2"	-	1/2"	605

11-12-16 BAR -10°C PAINTED VERTICAL AIR VESSELS

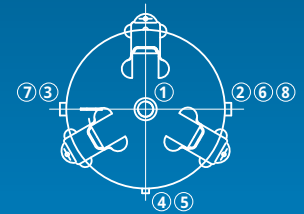
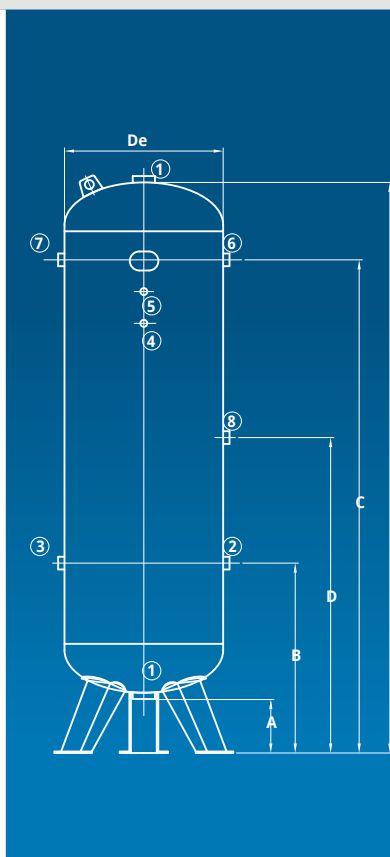

DIRECTIVE	2014/29/UE	2014/68/UE (PED)
OPERATING PRESSURE	11/16 BAR	12/16 BAR
OPERATING TEMPERATURE	-10 +100°C	-10 +50°C

- MATERIAL: CARBON STEEL
- FLUID CONTENT: COMPRESSED AIR / NITROGEN (GROUP 2)
- FINISHING: EXTERNAL RAL 5015 BLUE PAINT (STANDARD)

CODE	Directive	Capacity	Operating Pressure	De	A	B	C	D	L	1	2	3	4	5	6	7	8	Weight
RAL 5015		Lt	Bar	mm	mm	mm	mm	mm	mm	inch	inch	inch	inch	inch	inch	inch	inch	Kg
VEC00644	2014/29/UE	100	11	370	180	355	1055	=	1213	1/2"	3/4"	=	3/8"	3/8"	=	3/4"	=	31
VEC00709	2014/29/UE	150	11	396	170	385	1210	=	1430	1/2"	1"	=	3/8"	3/8"	=	1"	=	44
VEC02071	2014/29/UE	200	11	446	175	400	1225	=	1557	2"	1"	=	3/8"	3/8"	=	1"	=	55
VEC00795	2014/29/UE	270	11	500	175	599	1304	=	1648	2"	1"	1"	=	3/8"	1"	=	=	67
VEC00493	2014/29/UE	500	11	600	155	785	1665	=	2050	1/2"	1"	1"	=	3/8"	1"	1"	=	115
VEC00370	2014/29/UE	500	11	600	155	785	1665	=	2050	2"	2"	2"	=	3/8"	2"	2"	=	116
VEC00507	2014/29/UE	720	11	750	135	880	1705	=	2030	2"	1"	1"	3/8"	3/8"	1"	1"	=	178
VEC00510	2014/29/UE	720	11	750	135	880	1705	=	2030	2"	2"	2"	3/8"	3/8"	2"	2"	=	178
VEC00511	2014/29/UE	900	11	800	145	875	1805	=	2140	2"	1 1/2"	1 1/2"	3/8"	3/8"	1 1/2"	1 1/2"	=	194
VEC02045	2014/29/UE	900	11	800	145	875	1805	=	2140	2"	2"	2"	3/8"	3/8"	2"	2"	=	194
VEC00518	2014/68/UE (PED)	1000	12	800	145	770	1720	=	2350	2"	2"	2"	3/8"	3/8"	2"	2"	=	210
VEC00525	2014/68/UE (PED)	1500	12	1000	170	680	1780	=	2305	2"	2"	2"	1/2"	1/2"	2"	2"	=	320
VEC00528	2014/68/UE (PED)	2000	12	1100	200	770	1970	=	2490	2"	2"	2"	1/2"	1/2"	2"	2"	=	388
VEC00530	2014/68/UE (PED)	2000	12	1100	200	770	1970	=	2490	2"	3"	3"	1/2"	1/2"	3"	3"	=	390
VEC00535	2014/68/UE (PED)	3000	12	1200	140	830	2250	1540	2990	2"	2"	2"	1/2"	1/2"	2"	2"	2"	594
VEC01360	2014/68/UE (PED)	3000	12	1200	140	830	2250	1540	2990	2"	3"	3"	1/2"	1/2"	3"	3"	3"	596

11-12-16 BAR -10°C GALVANIZED VERTICAL AIR VESSELS

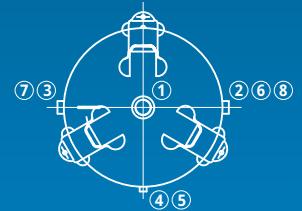
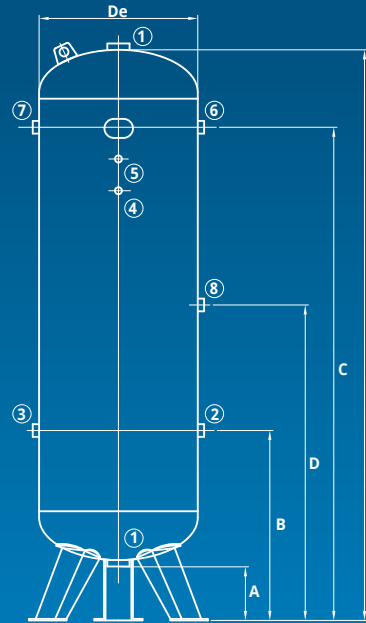

DIRECTIVE	2014/29/UE	2014/68/UE (PED)
OPERATING PRESSURE	11/16 BAR	12/16 BAR
OPERATING TEMPERATURE	-10 +100°C	-10 +50°C

- MATERIAL: CARBON STEEL SUITABLE FOR GALVANIZATION
- FLUID CONTENT: COMPRESSED AIR / NITROGEN (GROUP 2)
- FINISHING: INTERNAL AND EXTERNAL HOT-DIP GALVANIZATION

CODE	Directive	Capacity	Operating Pressure	De	A	B	C	D	L	1	2	3	4	5	6	7	8	Weight
GALVANIZED		Lt	Bar	mm	mm	mm	mm	mm	mm	inch	inch	inch	inch	inch	inch	inch	inch	Kg
VEC00901	2014/29/UE	100	11	370	170	355	1055	-	1213	2"	3/4"	-	3/8"	3/8"	-	3/4"	-	32
VEC00908	2014/29/UE	200	11	446	170	400	1225	-	1557	2"	1"	-	3/8"	3/8"	-	1"	-	57
VEC00909	2014/29/UE	270	11	500	170	599	1304	-	1648	2"	1"	1"	-	3/8"	1"	-	-	70
VEC00906	2014/29/UE	500	11	600	155	785	1665	-	2050	2"	2"	2"	-	3/8"	2"	2"	-	119
VEC00907	2014/29/UE	720	11	750	135	880	1705	-	2030	2"	2"	2"	3/8"	3/8"	2"	2"	-	181
VEC00512	2014/29/UE	900	11	800	145	875	1805	-	2140	2"	1"1/2	1"1/2	3/8"	3/8"	1"1/2	1"1/2	-	198
VEC00519	2014/68/UE (PED)	1000	12	800	145	770	1720	-	2350	2"	2"	2"	3/8"	3/8"	2"	2"	-	214
VEC00526	2014/68/UE (PED)	1500	12	1000	170	680	1780	-	2305	2"	2"	2"	1/2"	1/2"	2"	2"	-	325
VEC00529	2014/68/UE (PED)	2000	12	1100	200	770	1970	-	2490	2"	2"	2"	1/2"	1/2"	2"	2"	-	394
VEC00536	2014/68/UE (PED)	3000	12	1200	140	830	2250	1540	2990	2"	2"	2"	1/2"	1/2"	2"	2"	2"	600
VEC00900	2014/29/UE	270	16	500	170	599	1304	-	1648	2"	1"	1"	-	3/8"	1"	-	-	104
VEC00500	2014/29/UE	500	16	600	155	785	1665	-	2050	2"	2"	2"	-	3/8"	2"	2"	-	149
VEC00402	2014/68/UE (PED)	1000	16	800	150	770	1720	-	2350	2"	2"	2"	3/8"	3/8"	2"	2"	-	249
VEC02278	2014/68/UE (PED)	1500	16	1000	170	680	1780	-	2305	2"	2"	2"	1/2"	1/2"	2"	2"	-	428
VEC00533	2014/68/UE (PED)	2000	16	1000	170	770	2185	-	2740	2"	2"	2"	1/2"	1/2"	2"	2"	-	455
VEC00538	2014/68/UE (PED)	3000	16	1200	140	830	2250	1540	2990	2"	2"	2"	1/2"	1/2"	2"	2"	2"	635

11-12-16 BAR -10°C VERTICAL AIR VESSELS WITH INTERNAL ALM PAINT

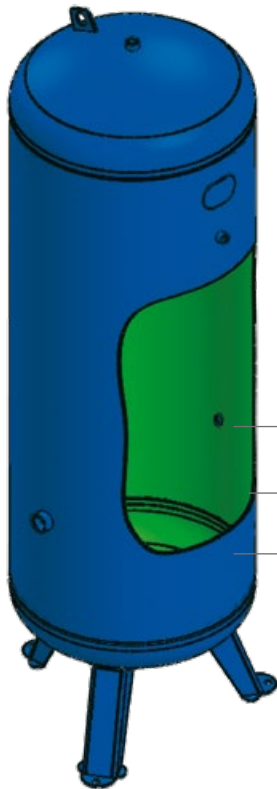

ALM RAL 5005

CARBON STEEL

RAL 5015

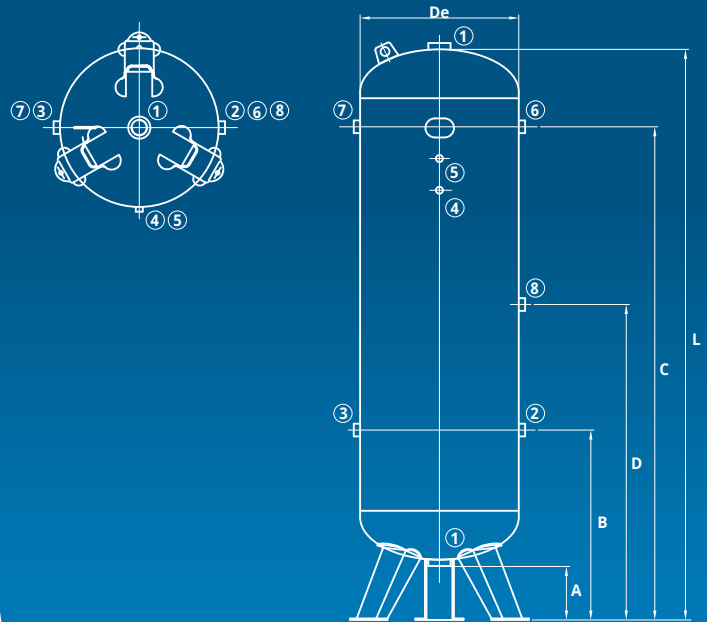

DIRECTIVE	2014/29/UE	2014/68/UE (PED)
OPERATING PRESSURE	11/16 BAR	12/16 BAR
OPERATING TEMPERATURE	-10 +100°C	-10 +50°C

- MATERIAL: CARBON STEEL
- FLUID CONTENT: COMPRESSED AIR / NITROGEN (GROUP 2)
- FINISHING: EXTERNAL RAL 5015 BLUE PAINT (STANDARD) AND INTERNAL RAL 5005 ALM PAINT

CODE	Directive	Capacity	Operating Pressure	De	A	B	C	D	L	1	2	3	4	5	6	7	8	Weight
ALM		Lt	Bar	mm	mm	mm	mm	mm	mm	inch	inch	inch	inch	inch	inch	inch	inch	Kg
VEC01125	2014/29/UE	270	11	500	170	599	1304	=	1648	2"	1"	1"	=	3/8"	1"	=	=	67
VEC01118	2014/29/UE	500	11	600	155	785	1665	=	2050	2"	2"	2"	=	3/8"	2"	2"	=	116
VEC01119	2014/29/UE	720	11	750	135	880	1705	=	2030	2"	2"	2"	3/8"	3/8"	2"	2"	=	178
VEC01120	2014/29/UE	900	11	800	145	875	1805	=	2140	2"	1/2"	1/2"	3/8"	3/8"	1"1/2"	1"1/2"	=	194
VEC01116	2014/68/UE (PED)	1000	12	800	145	770	1720	=	2350	2"	2"	2"	3/8"	3/8"	2"	2"	=	210
VEC01121	2014/68/UE (PED)	1500	12	1000	170	680	1780	=	2305	2"	2"	2"	1/2"	1/2"	2"	2"	=	320
VEC01122	2014/68/UE (PED)	2000	12	1100	200	770	1970	=	2490	2"	2"	2"	1/2"	1/2"	2"	2"	=	388
VEC01123	2014/68/UE (PED)	3000	12	1200	140	830	2250	1540	2990	2"	2"	2"	1/2"	1/2"	2"	2"	2"	594
VEC01935	2014/29/UE	270	16	500	175	599	1304	=	1648	2"	1"	1"	=	3/8"	1"	=	=	101
VEC02279	2014/29/UE	500	16	600	155	785	1665	=	2050	2"	2"	2"	=	3/8"	2"	2"	=	145
VEC02310	2014/68/UE (PED)	1000	16	800	145	770	1720	=	2350	2"	2"	2"	3/8"	3/8"	2"	2"	=	245
VEC02143	2014/68/UE (PED)	2000	16	1000	170	770	2185	=	2740	2"	2"	2"	1/2"	1/2"	2"	2"	=	450
VEC02464	2014/68/UE (PED)	3000	16	1200	140	830	2250	1540	2990	2"	2"	2"	1/2"	1/2"	2"	2"	2"	630

VACUUM VERTICAL AIR VESSELS

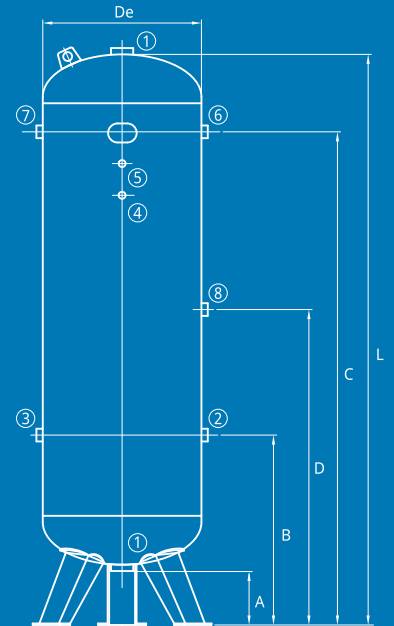
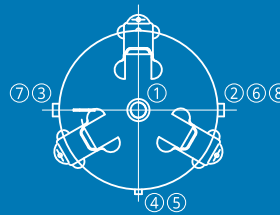

DIRECTIVE MANUFACTURER TESTING
OPERATING PRESSURE -1 BAR
OPERATING TEMPERATURE -10 +100°C

- MATERIAL: CARBON STEEL
- SUITABLE FOR VACUUM PUMPS AND UNITS
- FINISHING: EXTERNAL RAL 5015 BLUE PAINT (STANDARD)

CODE	Directive	Capacity	Operating Pressure	De	A	B	C	D	L	1	2	3	4	5	6	7-8	Weight
		Lt	Bar	mm	mm	mm	mm	mm	mm	inch	inch	inch	inch	inch	inch	inch	Kg
VAC00041	-----	100	-1	370	180	355	1055	=	1213	2"	3/4"	=	3/8"	3/8"	=	3/4"	40
VAC00012	-----	270	-1	500	170	599	1304	=	1648	2"	1"	1"	=	3/8"	1"	=	101
VAC00005	-----	500	-1	600	155	785	1665	=	2050	2"	2"	2"	=	3/8"	2"	2"	145
VAC00004	-----	1000	-1	800	145	760	1700	=	2350	2"	2"	2"	3/8"	3/8"	2"	2"	245
VAC00006	-----	2000	-1	1100	200	770	1970	=	2490	2"	2"	2"	1/2"	1/2"	2"	2"	450
VAC00013	-----	3000	-1	1200	140	830	2250	1540	2990	2"	2"	2"	1/2"	1/2"	2"	2"	630

A VACUUM SYSTEM IS REQUIRED IN CERTAIN INDUSTRIAL PROCESS OPERATIONS IN ORDER TO PREVENT CHEMICAL OR PHYSICAL PROCESSES CAUSED BY THE ACTION OF ATMOSPHERIC GASES.

THE VESSELS ARE USED TO REPRODUCE A SETTING WHERE GAS PRESSURE IS LOWER THAN THE ATMOSPHERIC ONE. VACUUM VESSELS ARE NOT GOVERNED BY ANY DIRECTIVE AND ARE THEREFORE EXCLUDED FROM CE MARKING REQUIREMENTS.

ALL VESSELS ARE SUPPLIED WITH NAME PLATE BEARING MANUFACTURER'S NAME, OPERATING TEMPERATURE, OPERATING PRESSURE AND PRODUCT'S SERIAL NUMBER.



11-12-16 BAR -20°C PAINTED VERTICAL AIR VESSELS

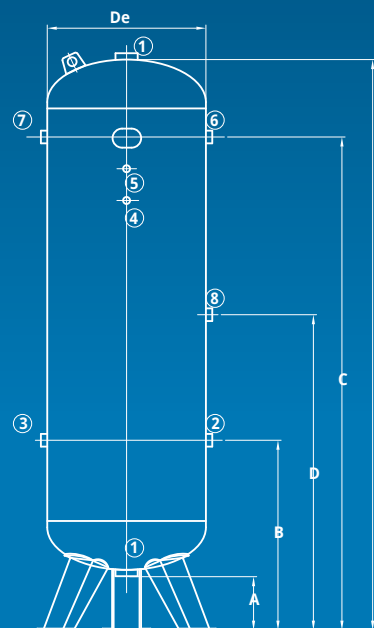
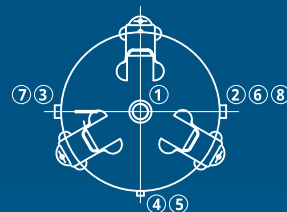

DIRECTIVE	2014/68/UE (PED)	2014/68/UE (PED)
OPERATING PRESSURE	11/16 BAR	12/16 BAR
OPERATING TEMPERATURE	* -20 +50°C	-20 +80°C

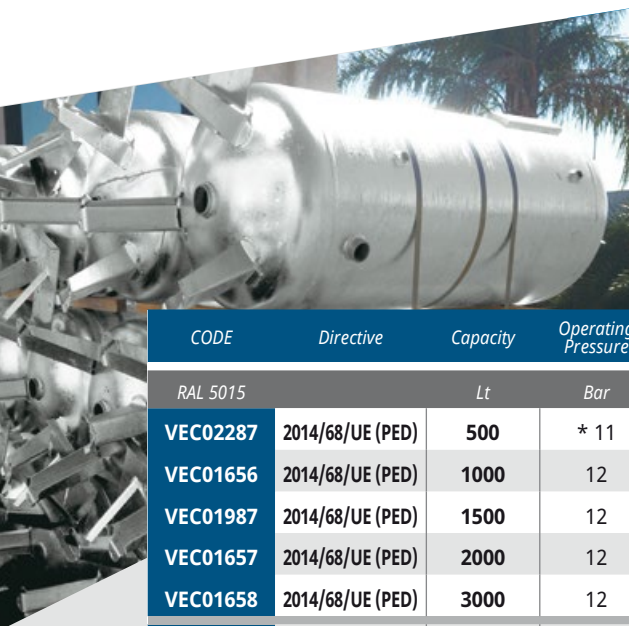

- MATERIAL: CARBON STEEL
- FLUID CONTENT: COMPRESSED AIR / NITROGEN / ARGON / HELIUM / OIL / OXYGEN (GROUP 1 - HYDROGEN AND WATER EXCLUDED)
- FINISHING: EXTERNAL RAL 5015 BLUE PAINT (STANDARD)
- UPON REQUEST: INSPECTION PORTS - 100x150 mm HANDHOLE (FROM 1000 TO 3000 lt)

CODE	Directive	Capacity	Operating Pressure	De	A	B	C	L	1	2	3	4	5	6	7	Weight
RAL 5015		Lt	Bar	mm	mm	mm	mm	mm	mm	mm	mm	inch	inch	inch	inch	Kg
VEC02287	2014/68/UE (PED)	500	* 11	600	155	785	1665	2050	2"	2"	2"	=	3/8"	2"	2"	116
VEC01656	2014/68/UE (PED)	1000	12	800	145	770	1720	2350	2"	2"	2"	3/8"	3/8"	2"	2"	210
VEC01987	2014/68/UE (PED)	1500	12	1000	170	680	1780	2305	2"	2"	2"	1/2"	1/2"	2"	2"	320
VEC01657	2014/68/UE (PED)	2000	12	1100	200	770	1970	2490	2"	2"	2"	1/2"	1/2"	2"	2"	388
VEC01658	2014/68/UE (PED)	3000	12	1200	140	830	2250	2990	2"	2"	2"	1/2"	1/2"	2"	2"	594
VEC02289	2014/68/UE (PED)	500	* 16	600	155	785	1665	2050	2"	2"	2"	=	3/8"	2"	2"	145
VEC01918	2014/68/UE (PED)	1000	16	800	145	770	1720	2350	2"	2"	2"	3/8"	3/8"	2"	2"	245
VEC02290	2014/68/UE (PED)	1500	16	1000	170	680	1780	2305	2"	2"	2"	1/2"	1/2"	2"	2"	423
VEC02288	2014/68/UE (PED)	2000	16	1100	200	770	1970	2490	2"	2"	2"	1/2"	1/2"	2"	2"	450
VEC02051	2014/68/UE (PED)	3000	16	1200	140	830	2250	2990	2"	2"	2"	1/2"	1/2"	2"	2"	630

-20°C GALVANIZED / ALM-PAINTED / OXYGEN VERTICAL AIR VESSELS

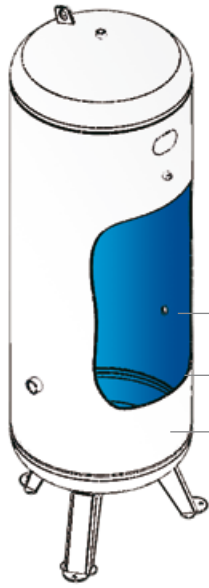

ALM RAL 5005
CARBON STEEL
RAL 9010

DIRECTIVE	2014/68/UE (PED)	2014/68/UE (PED)
OPERATING PRESSURE	11 BAR	12 BAR
OPERATING TEMPERATURE	* -20 +50°C	-20 +80°C

- MATERIAL: CARBON STEEL
- FLUID CONTENT: OXYGEN (GROUP 1 - HYDROGEN AND WATER EXCLUDED)
- OXIGEN FINISHING: EXTERNAL RAL 9010 WHITE PAINT AND INTERNAL RAL 5005 CORROSION-RESISTANT ALM PAINT
- GALVANIZED FINISHING: INTERNAL AND EXTERNAL HOT-DIP
- GALVANIZATION ALM FINISHING: EXTERNAL RAL5015 BLUE PAINT (STANDARD) AND INTERNAL RAL5005 CORROSION-RESISTANT ALM PAINT

CODE	Directive	Capacity	Operating Pressure	De	A	B	C	L	1	2	3	4	5	6	7	Weight
		Lt	Bar	mm	mm	mm	mm	mm	mm	mm	mm	inch	inch	inch	inch	Kg
GALVANIZED																
VEC02291	2014/68/UE (PED)	500	* 11	600	155	785	1665	2050	2"	2"	2"	=	3/8"	2"	2"	119
VEC02292	2014/68/UE (PED)	1000	12	800	145	770	1720	2350	2"	2"	2"	3/8"	3/8"	2"	2"	214
VEC02293	2014/68/UE (PED)	1500	12	1000	170	680	1780	2305	2"	2"	2"	1/2"	1/2"	2"	2"	325
VEC02294	2014/68/UE (PED)	2000	12	1100	200	770	1970	2490	2"	2"	2"	1/2"	1/2"	2"	2"	394
VEC02295	2014/68/UE (PED)	3000	12	1200	140	830	2250	2990	2"	2"	2"	1/2"	1/2"	2"	2"	600
VEC02296	2014/68/UE (PED)	500	* 11	600	155	785	1665	2050	2"	2"	2"	=	3/8"	2"	2"	149
VEC02297	2014/68/UE (PED)	1000	12	800	145	770	1720	2350	2"	2"	2"	3/8"	3/8"	2"	2"	249
VEC02298	2014/68/UE (PED)	1500	12	1000	170	680	1780	2305	2"	2"	2"	1/2"	1/2"	2"	2"	428
VEC02299	2014/68/UE (PED)	2000	12	1100	200	770	1970	2490	2"	2"	2"	1/2"	1/2"	2"	2"	455
VEC02300	2014/68/UE (PED)	3000	12	1200	140	830	2250	2990	2"	2"	2"	1/2"	1/2"	2"	2"	635
ALM																
VEC02302	2014/68/UE (PED)	500	* 11	600	155	785	1665	2050	2"	2"	2"	=	3/8"	2"	2"	116
VEC02303	2014/68/UE (PED)	1000	12	800	145	770	1720	2350	2"	2"	2"	3/8"	3/8"	2"	2"	210
VEC02304	2014/68/UE (PED)	1500	12	1000	170	680	1780	2305	2"	2"	2"	1/2"	1/2"	2"	2"	320
VEC02305	2014/68/UE (PED)	2000	12	1100	200	770	1970	2490	2"	2"	2"	1/2"	1/2"	2"	2"	388
VEC02306	2014/68/UE (PED)	3000	12	1200	140	830	2250	2990	2"	2"	2"	1/2"	1/2"	2"	2"	594
VEC02307	2014/68/UE (PED)	500	* 16	600	155	785	1665	2050	2"	2"	2"	=	3/8"	2"	2"	145
VEC02074	2014/68/UE (PED)	1000	16	800	145	770	1720	2350	2"	2"	2"	3/8"	3/8"	2"	2"	245
VEC02308	2014/68/UE (PED)	1500	16	1000	170	680	1780	2305	2"	2"	2"	1/2"	1/2"	2"	2"	423
VEC02309	2014/68/UE (PED)	2000	16	1100	200	770	1970	2490	2"	2"	2"	1/2"	1/2"	2"	2"	450
VEC02247	2014/68/UE (PED)	3000	16	1200	140	830	2250	2990	2"	2"	2"	1/2"	1/2"	2"	2"	630
RAL 9010 / RAL 5005																
VEC02176	2014/68/UE (PED)	500	* 11	600	155	785	1665	2050	2"	2"	2"	=	3/8"	2"	2"	116
VEC03412	2014/68/UE (PED)	800	12	800	145	875	1605	1940	2"	2"	2"	3/8"	3/8"	2"	2"	180
VEC01719	2014/68/UE (PED)	1000	12	800	145	770	1720	2350	2"	2"	2"	3/8"	3/8"	2"	2"	210
VEC01720	2014/68/UE (PED)	1500	12	1000	170	680	1780	2305	2"	2"	2"	1/2"	1/2"	2"	2"	320
VEC01721	2014/68/UE (PED)	2000	12	1100	200	770	1970	2490	2"	2"	2"	1/2"	1/2"	2"	2"	388
VEC01722	2014/68/UE (PED)	3000	12	1200	140	830	2250	2990	2"	2"	2"	1/2"	1/2"	2"	2"	594

-20°C OVERSIZE PAINTED VERTICAL AIR VESSELS

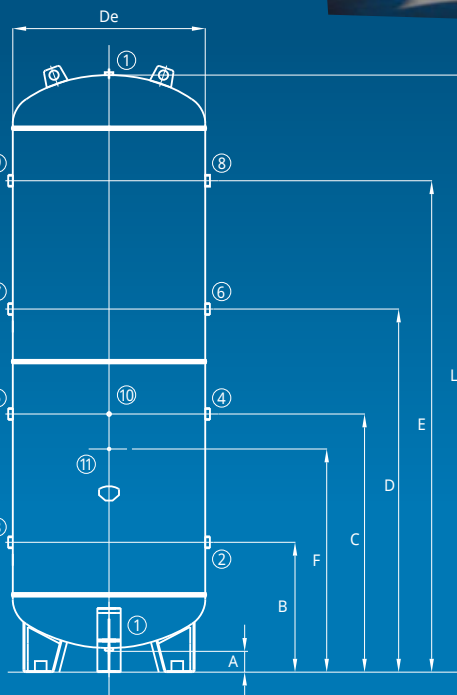
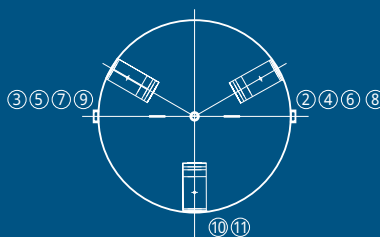

DIRECTIVE 2014/68/UE (PED)

OPERATING PRESSURE 8/12/16 BAR

OPERATING TEMPERATURE -20 +80°C

- MATERIAL: CARBON STEEL
- FLUID CONTENT: COMPRESSED AIR / NITROGEN / ARGON / HELIUM / OIL / OXYGEN (GROUP 1 - HYDROGEN AND WATER EXCLUDED)
- FINISHING: EXTERNAL RAL 5015 BLUE PAINT (STANDARD)
- UPON REQUEST: INSPECTION PORTS - 100x150 mm
HANDHOLE - 300x400 mm MANHOLE

CODE	Directive	Capacity	Operating Pressure	De	A	B	C	D	E	F	L	1	2-3-4-5	6-7-8-9	10	11	Weight
RAL 5015		Lt	Bar	mm	mm	mm	mm	mm	inch	inch	inch	inch	inch	inch	inch	inch	Kg
VEC02191	2014/68/UE (PED)	5000	8	1650	175	1150	2200	=	=	1950	3200	2"	3"	=	3/4"	3/8"	1120
VEC02280	2014/68/UE (PED)	8000	8	1650	175	1150	1930	2460	3310	1680	4315	2"	3"	3"	3/4"	3/8"	1400
VEC02192	2014/68/UE (PED)	10000	8	1650	175	1150	2200	3150	4250	1950	5200	2"	3"	3"	3/4"	3/8"	1730
VEC01297	2014/68/UE (PED)	4000	12	1450	225	800	2145	=	=	=	2790	2"	3"	=	3/4"	3/8"	835
VEC01298	2014/68/UE (PED)	5000	12	1450	225	800	2745	=	=	=	3390	2"	3"	=	3/4"	3/8"	962
VEC00755	2014/68/UE (PED)	5000	12	1650	175	1150	2200	=	=	1950	3200	2"	3"	=	3/4"	3/8"	1360
VEC01299	2014/68/UE (PED)	6000	12	1450	225	800	3345	=	=	=	3990	2"	3"	=	3/4"	3/8"	1090
VEC01300	2014/68/UE (PED)	8000	12	1650	175	1150	1930	2460	3310	1680	4315	2"	3"	3"	3/4"	3/8"	1730
VEC00815	2014/68/UE (PED)	10000	12	1650	175	1150	2200	3150	4250	1950	5200	2"	3"	3"	3/4"	3/8"	2015
VEC02666	2014/68/UE (PED)	4000	16	1450	225	800	2145	=	=	=	2790	2"	3"	=	3/4"	3/8"	995
VEC02667	2014/68/UE (PED)	5000	16	1450	225	800	2745	=	=	=	3390	2"	3"	=	3/4"	3/8"	1145
VEC02668	2014/68/UE (PED)	6000	16	1450	225	800	3345	=	=	=	3990	2"	3"	=	3/4"	3/8"	1295
VEC01899	2014/68/UE (PED)	10000	16	1650	175	1150	2200	3150	4250	1950	5200	2"	3"	3"	3/4"	3/8"	2585

-20°C OVERSIZE GALVANIZED / ALM-PAINTED / OXYGEN VERTICAL AIR VESSELS



DIRECTIVE 2014/68/UE (PED)
OPERATING PRESSURE 8/12/16 BAR
OPERATING TEMPERATURE -20 +80°C

- MATERIAL: CARBON STEEL
- FLUID CONTENT: COMPRESSED AIR / NITROGEN / ARGON / HELIUM / OIL / OXYGEN (GROUP 1 - HYDROGEN AND WATER EXCLUDED)
- GALVANIZED FINISHING: INTERNAL AND EXTERNAL HOT-DIP GALVANIZATION
- ALM FINISHING: EXTERNAL RAL 5015 BLUE PAINT (STANDARD) AND INTERNAL RAL 5005 CORROSION-RESISTANT ALM PAINT
- OXYGEN FINISHING: EXTERNAL RAL9010 WHITE PAINT AND INTERNAL RAL5005 CORROSION-RESISTANT ALM PAINT
- UPON REQUEST: INSPECTION PORTS - 100x150 mm HANDHOLE (FROM 1000 TO 3000 lt)

CODE	Directive	Capacity	Operating Pressure	De	A	B	C	D	E	F	L	1	2-3-4-5	6-7-8-9	10	11	Weight
GALVANIZED		Lt	Bar	mm	mm	mm	mm	mm	inch	inch	inch	inch	inch	inch	inch	inch	Kg
VEC02281	2014/68/UE (PED)	5000	8	1650	175	1150	2200	=	=	1950	3200	2"	3"	=	3/4"	3/8"	1120
VEC02283	2014/68/UE (PED)	10000	8	1650	175	1150	2200	3150	4250	1950	5200	2"	3"	3"	3/4"	3/8"	1730
VEC01725	2014/68/UE (PED)	4000	12	1450	225	800	2145	=	=	=	2790	2"	3"	=	3/4"	3/8"	835
VEC01726	2014/68/UE (PED)	5000	12	1450	225	800	2745	=	=	=	3390	2"	3"	=	3/4"	3/8"	962
VEC00856	2014/68/UE (PED)	5000	12	1650	175	1150	2200	=	=	1950	3200	2"	3"	=	3/4"	3/8"	1360
VEC01395	2014/68/UE (PED)	6000	12	1450	225	800	3345	=	=	=	3990	2"	3"	=	3/4"	3/8"	1090
VEC01727	2014/68/UE (PED)	8000	12	1650	175	1150	1930	2460	3310	1680	4315	2"	3"	3"	3/4"	3/8"	1730
VEC00982	2014/68/UE (PED)	10000	12	1650	175	1150	2200	3150	4250	1950	5200	2"	3"	3"	3/4"	3/8"	2016
VEC01728	2014/68/UE (PED)	4000	16	1450	225	800	2145	=	=	=	2790	2"	3"	=	3/4"	3/8"	995
VEC01729	2014/68/UE (PED)	5000	16	1450	225	800	2745	=	=	=	3390	2"	3"	=	3/4"	3/8"	1145
VEC01730	2014/68/UE (PED)	6000	16	1450	225	800	3345	=	=	=	3990	2"	3"	=	3/4"	3/8"	1295
VEC02467	2014/68/UE (PED)	10000	16	1650	175	1150	2200	3150	4250	1950	5200	2"	3"	3"	3/4"	3/8"	2585

CODE	Directive	Capacity	Operating Pressure	De	A	B	C	D	E	F	L	1	2-3-4-5	6-7-8-9	10	11	Weight
ALM		Lt	Bar	mm	mm	mm	mm	mm	inch	inch	inch	inch	inch	inch	inch	inch	Kg
VEC01614	2014/68/UE (PED)	4000	12	1450	225	800	2145	=	=	=	2790	2"	3"	=	3/4"	3/8"	835
VEC01344	2014/68/UE (PED)	5000	12	1450	225	800	2745	=	=	=	3390	2"	3"	=	3/4"	3/8"	962
VEC01124	2014/68/UE (PED)	5000	12	1650	175	1150	2200	=	=	1950	3200	2"	3"	=	3/4"	3/8"	1360
VEC04723	2014/68/UE (PED)	10000	12	1650	175	1150	2200	3150	4250	1950	5200	2"	3"	3"	3/4"	3/8"	2016
VEC02465	2014/68/UE (PED)	4000	16	1450	225	800	2145	=	=	=	2790	2"	3"	=	3/4"	3/8"	995
VEC02466	2014/68/UE (PED)	5000	16	1450	225	800	2745	=	=	=	3390	2"	3"	=	3/4"	3/8"	1145

CODE	Directive	Capacity	Operating Pressure	De	A	B	C	D	E	F	L	1	2-3-4-5	6-7-8-9	10	11	Weight
RAL 9010 / RAL 5005		Lt	Bar	mm	mm	mm	mm	mm	inch	inch	inch	inch	inch	inch	inch	inch	Kg
VEC01723	2014/68/UE (PED)	4000	12	1450	225	800	2145	=	=	=	2790	2"	3"	=	3/4"	3/8"	835
VEC01724	2014/68/UE (PED)	5000	12	1450	225	800	2745	=	=	=	3390	2"	3"	=	3/4"	3/8"	962

-20°C OVERSIZE PAINTED / ALM-PAINTED HORIZONTAL AIR VESSELS

DIRECTIVE	2014/68/UE (PED)
OPERATING PRESSURE	12 BAR
OPERATING TEMPERATURE	-20 +80°C

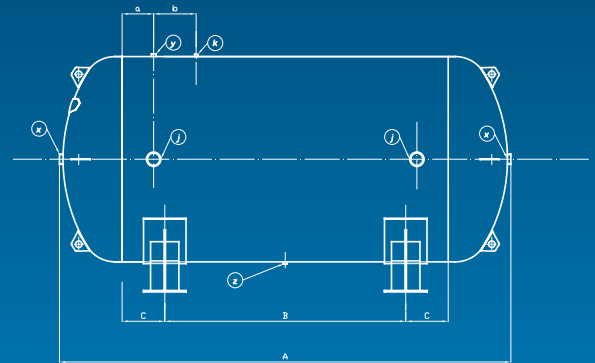
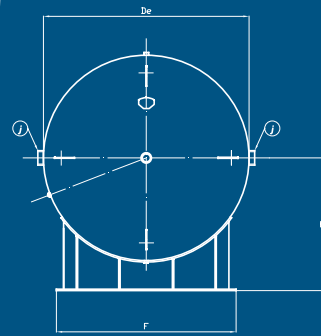

- **MATERIAL: CARBON STEEL**
- **FLUID CONTENT: COMPRESSED AIR / NITROGEN / ARGON / HELIUM / OIL / OXYGEN (GROUP 1 - HYDROGEN AND WATER EXCLUDED)**
- **GALVANIZED FINISHING: INTERNAL AND EXTERNAL HOT-DIP GALVANIZATION**
- **ALM FINISHING: EXTERNAL RAL 5015 BLUE PAINT (STANDARD) AND INTERNAL RAL 5005 CORROSION-RESISTANT ALM PAINT**
- **UPON REQUEST: INSPECTION PORTS - 100x150 mm HANDHOLE (FROM 1000 TO 3000 lt) - 300x400 mm MANHOLE**

CODE	Directive	Capacity	Operating Pressure	De	A	B	C	F	H	a	b	x	y	k	j	z	Weight
RAL 5015		Lt	Bar	mm	mm	mm	mm	mm	mm	mm	mm	inch	inch	inch	inch	inch	Kg
VEC02410	2014/68/UE (PED)	5000	12	1450	3184	1700	300	1267	937	222	300	2"	3/4"	3/8"	3"	1/2"	1060
VEC00772	2014/68/UE (PED)	5000	12	1650	2962	1300	350	1267	1035	300	450	2"	3/4"	3/8"	3"	1/2"	1380
VEC02313	2014/68/UE (PED)	10000	12	1650	4912	2080	1000	1267	1035	450	300	2"	3/4"	3/8"	3"	2"	2240
GALVANIZED		Lt	Bar	mm	mm	mm	mm	mm	mm	mm	mm	inch	inch	inch	inch	inch	Kg
VEC04698	2014/68/UE (PED)	5000	12	1450	3184	1700	300	1267	937	222	300	2"	3/4"	3/8"	3"	1/2"	1100
VEC04699	2014/68/UE (PED)	5000	12	1650	2962	1300	350	1267	1035	300	450	2"	3/4"	3/8"	3"	1/2"	1410
VEC04701	2014/68/UE (PED)	10000	12	1650	4912	2080	1000	1267	1035	450	300	2"	3/4"	3/8"	3"	2"	2320
ALM		Lt	Bar	mm	mm	mm	mm	mm	mm	mm	mm	inch	inch	inch	inch	inch	Kg
VEC02833	2014/68/UE (PED)	5000	12	1450	3184	1700	300	1267	937	222	300	2"	3/4"	3/8"	3"	1/2"	1060
VEC04700	2014/68/UE (PED)	5000	12	1650	2962	1300	350	1267	1035	300	450	2"	3/4"	3/8"	3"	1/2"	1380

21 BAR -20°C PAINTED / ALM-PAINTED VERTICAL AIR VESSELS

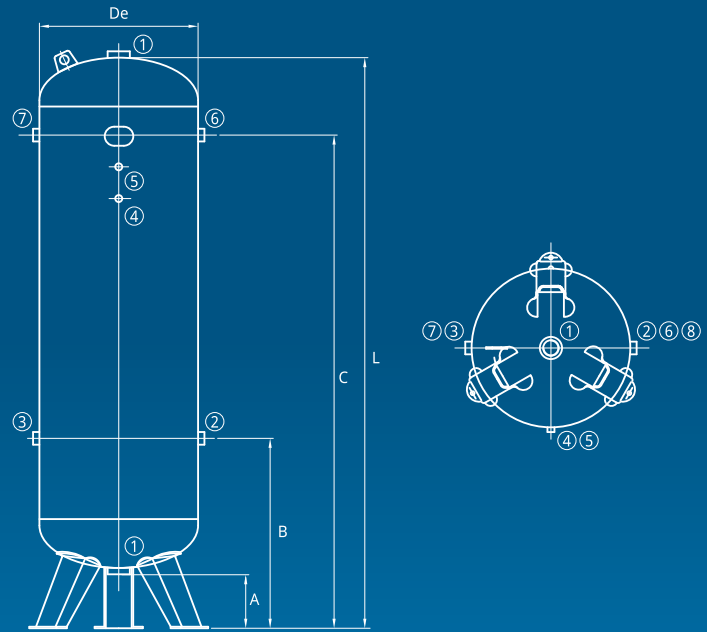

DIRECTIVE 2014/29/UE
OPERATING PRESSURE 21 BAR
OPERATING TEMPERATURE -20 +100°C

- MATERIAL: CARBON STEEL
- FLUID CONTENT: COMPRESSED AIR / NITROGEN (GROUP 2)
- FINISHING: EXTERNAL RAL 5015 BLUE PAINT (STANDARD)
- GALVANIZED FINISHING: INTERNAL AND EXTERNAL HOT-DIP GALVANIZATION

CODE	Directive	Capacity	Operating Pressure	De	A	B	C	L	1	2	3	4	5	6	7	Weight
RAL 5015		Lt	Bar	mm	mm	mm	mm	mm	inch	inch	inch	inch	inch	inch	inch	Kg
VEC00883	2014/29/UE	120	21	396	170	385	1210	1430	2"	1"	=	3/8"	3/8"	=	1"	58
VEC00884	2014/29/UE	250	21	500	300	545	1515	1790	2"	3/4"	3/4"	1/4"	3/4"	3/4"	=	108
VEC01470	2014/29/UE	475	21	600	155	785	1665	2050	2"	2"	2"	=	3/8"	2"	2"	220
GALVANIZED		Lt	Bar	mm	mm	mm	mm	mm	inch	inch	inch	inch	inch	inch	inch	Kg
VEC02438	2014/29/UE	120	21	396	170	385	1210	1430	2"	1"	=	3/8"	3/8"	=	=	58
VEC02433	2014/29/UE	250	21	500	300	545	1515	1790	2"	3/4"	3/4"	1/4"	3/4"	3/4"	=	110
VEC02434	2014/29/UE	475	21	600	155	785	1665	2050	2"	2"	2"	=	3/8"	2"	2"	224

DIRECTIVE 2014/68/UE (PED)
OPERATING PRESSURE 21 BAR
OPERATING TEMPERATURE -20 +50°C

- MATERIAL: CARBON STEEL
- FLUID CONTENT: COMPRESSED AIR / NITROGEN / ARGON / HELIUM / OIL / OXYGEN (GROUP 1 - HYDROGEN AND WATER EXCLUDED)
- FINISHING: EXTERNAL RAL 5015 BLUE PAINT (STANDARD)
- GALVANIZED FINISHING: INTERNAL AND EXTERNAL HOT-DIP GALVANIZATION
- UPON REQUEST: INSPECTION PORTS - 100x150 mm HANDHOLE (FROM 1000 TO 3000 Lt) - GALVANIZATION AND ALM PAINTING

CODE	Directive	Capacity	Operating Pressure	De	A	B	C	L	1	2	3	4	5	6	7	Weight
RAL 5015		Lt	Bar	mm	mm	mm	mm	mm	inch	inch	inch	inch	inch	inch	inch	Kg
VEC02275	2014/68/UE(PED)	1000	21	800	145	770	1720	2350	2"	2"	2"	3/8"	3/8"	2"	2"	352
VEC04155	2014/68/UE(PED)	3000	21	1200	140	830	2250	2990	2"	2"	2"	1/2"	1/2"	2"	2"	1250
GALVANIZED		Lt	Bar	mm	mm	mm	mm	mm	inch	inch	inch	inch	inch	inch	inch	Kg
VEC02439	2014/68/UE(PED)	1000	21	800	145	770	1720	2350	2"	2"	2"	3/8"	3/8"	2"	2"	352
VEC04156	2014/68/UE(PED)	3000	21	1200	140	830	2250	2990	2"	2"	2"	1/2"	1/2"	2"	2"	1250

32 BAR -20°C PAINTED / ALM-PAINTED VERTICAL AIR VESSELS



DIRECTIVE	2014/68/UE (PED)
OPERATING PRESSURE	32 BAR
OPERATING TEMPERATURE	-20 +50°C

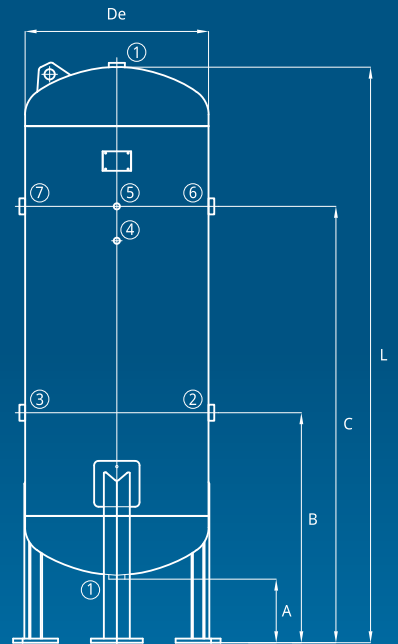

- MATERIAL: CARBON STEEL
- FLUID CONTENT: COMPRESSED AIR / NITROGEN / ARGON / HELIUM / OIL / OXYGEN (GROUP 1 - HYDROGEN AND WATER EXCLUDED)
- FINISHING: EXTERNAL RAL 5015 BLUE PAINT (STANDARD)
- GALVANIZED FINISHING: INTERNAL AND EXTERNAL HOT-DIP GALVANIZATION
- UPON REQUEST: INSPECTION PORTS - 100x150 mm HANDHOLE - 300x400 mm MANHOLE - GALVANIZATION AND ALM PAINTING

CODE	Directive	Capacity	Operating Pressure	De	A	B	C	L	1	2	3	4	5	6	7	Weight
		Lt	Bar	mm	mm	mm	mm	mm	inch	inch	inch	inch	inch	inch	inch	Kg
RAL 5015																
VEC02248	2014/68/UE (PED)	100	32	370	180	380	1055	1240	2"	3/4"	-	3/8"	3/8"	-	3/4"	88
VEC02249	2014/68/UE (PED)	270	32	500	175	600	1305	1673	2"	1"	1"	-	3/8"	1"	1"	192
VEC02250	2014/68/UE (PED)	500	32	600	155	785	1665	2063	2"	2"	2"	1/2"	1/2"	2"	2"	291
VEC02251	2014/68/UE (PED)	1000	32	800	145	770	1720	2375	2"	2"	2"	3/8"	3/8"	2"	2"	468
VEC02252	2014/68/UE (PED)	1500	32	1000	170	680	1780	2322	2"	2"	2"	1/2"	1/2"	2"	2"	663
VEC02253	2014/68/UE (PED)	2000	32	1100	200	880	1913	2576	2"	2"	2"	1/2"	1/2"	2"	2"	800
VEC02254	2014/68/UE (PED)	3000	32	1200	140	830	2250	2314	2"	2"	2"	1/2"	1/2"	2"	2"	1183
VEC02255	2014/68/UE (PED)	4000	32	1450	225	800	2145	2847	2"	3"	3"	3/4"	3/8"	3"	3"	1935
VEC02256	2014/68/UE (PED)	5000	32	1450	225	800	2745	3447	2"	3"	3"	3/4"	3/8"	3"	3"	2325
VEC02805	2014/68/UE (PED)	6000	32	1450	251	1000	2745	4053	2"	3"	3"	3/4"	3/8"	3"	3"	2700
GALVANIZED																
VEC02440	2014/68/UE(PED)	100	32	370	180	355	1055	1213	2"	3/4"	=	3/8"	3/8"	=	3/4"	89
VEC02441	2014/68/UE(PED)	270	32	500	175	599	1304	1648	2"	1"	1"	=	3/8"	1"	1"	192
VEC02442	2014/68/UE(PED)	500	32	600	155	785	1665	2050	2"	2"	2"	1/2"	1/2"	2"	2"	308
VEC02443	2014/68/UE(PED)	1000	32	800	145	770	1720	2350	2"	2"	2"	3/8"	3/8"	2"	2"	470
VEC02444	2014/68/UE(PED)	1500	32	1000	170	680	1780	2305	2"	2"	2"	1/2"	1/2"	2"	2"	665
VEC02446	2014/68/UE(PED)	2000	32	1000	170	770	2185	2740	2"	2"	2"	1/2"	1/2"	2"	2"	1100
VEC02447	2014/68/UE(PED)	3000	32	1200	140	830	2250	2990	2"	2"	2"	1/2"	1/2"	2"	2"	1535
VEC02448	2014/68/UE(PED)	4000	32	1450	225	800	2145	2790	2"	3"	3"	3/4"	3/8"	3"	3"	1950
VEC02450	2014/68/UE(PED)	5000	32	1450	225	800	2745	3390	2"	3"	3"	3/4"	3/8"	3"	3"	2280
VEC04704	2014/68/UE(PED)	6000	32	1450	251	1000	2745	4053	2"	3"	3"	3/4"	3/8"	3"	3"	2700

42 BAR -20°C PAINTED / ALM-PAINTED VERTICAL AIR VESSELS



DIRECTIVE 2014/68/UE (PED)
OPERATING PRESSURE 42 BAR
OPERATING TEMPERATURE -20 +50°C

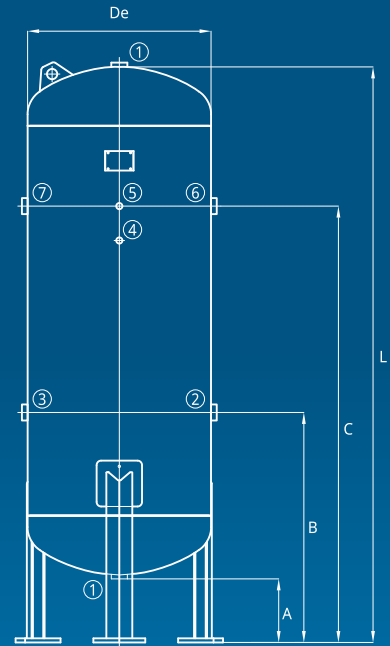

- MATERIAL: CARBON STEEL
- FLUID CONTENT: COMPRESSED AIR / NITROGEN / ARGON / HELIUM / OIL / OXYGEN (GROUP 1 - HYDROGEN AND WATER EXCLUDED)
- FINISHING: EXTERNAL RAL 5015 BLUE PAINT (STANDARD)
- GALVANIZED FINISHING: INTERNAL AND EXTERNAL HOT-DIP GALVANIZATION
- UPON REQUEST: INSPECTION PORTS - 100x150 mm HANDHOLE - 300x400 mm MANHOLE - GALVANIZATION AND ALM PAINTING

CODE	Directive	Capacity	Operating Pressure	De	A	B	C	L	1	2	3	4	5	6	7	Weight
RAL 5015		Lt	Bar	mm	mm	mm	mm	mm	inch	inch	inch	inch	inch	inch	inch	Kg
VEC02262	2014/68/UE (PED)	100	42	370	180	355	1055	1213	2"	3/4"	=	3/8"	3/8"	=	3/4"	100
VEC02263	2014/68/UE (PED)	200	42	446	200	430	1255	1587	2"	1"	=	1/2"	3/8"	=	1"	150
VEC02264	2014/68/UE (PED)	270	42	500	175	599	1304	1648	2"	1"	1"	=	3/8"	1"	1"	215
VEC02265	2014/68/UE (PED)	500	42	600	155	785	1665	2050	2"	2"	2"	1/2"	1/2"	2"	2"	355
VEC02266	2014/68/UE (PED)	1000	42	800	145	770	1720	2350	2"	2"	2"	3/8"	3/8"	2"	2"	675
VEC02267	2014/68/UE (PED)	1500	42	1000	170	680	1780	2305	2"	2"	2"	1/2"	1/2"	2"	2"	1100
VEC02268	2014/68/UE (PED)	2000	42	1100	200	770	1970	2490	2"	2"	2"	1/2"	1/2"	2"	2"	1460
VEC02269	2014/68/UE (PED)	3000	42	1200	140	830	2250	2990	2"	2"	2"	1/2"	1/2"	2"	2"	1950
VEC02270	2014/68/UE (PED)	4000	42	1450	225	800	2145	2790	2"	3"	3"	3/4"	3/8"	3"	3"	2540
VEC02271	2014/68/UE (PED)	5000	42	1450	225	800	2745	3390	2"	3"	3"	3/4"	3/8"	3"	3"	2845
GALVANIZED		Lt	Bar	mm	mm	mm	mm	mm	inch	inch	inch	inch	inch	inch	inch	Kg
VEC02452	2014/68/UE (PED)	100	42	370	180	355	1055	1213	2"	3/4"	=	3/8"	3/8"	=	3/4"	100
VEC02454	2014/68/UE (PED)	200	42	446	200	430	1255	1587	2"	1"	=	1/2"	3/8"	=	1"	150
VEC02455	2014/68/UE (PED)	270	42	500	175	599	1304	1648	2"	1"	1"	=	3/8"	1"	1"	215
VEC02456	2014/68/UE (PED)	500	42	600	155	785	1665	2050	2"	2"	2"	1/2"	1/2"	2"	2"	355
VEC02457	2014/68/UE (PED)	1000	42	800	145	770	1720	2350	2"	2"	2"	3/8"	3/8"	2"	2"	675
VEC02458	2014/68/UE (PED)	1500	42	1000	170	680	1780	2305	2"	2"	2"	1/2"	1/2"	2"	2"	1100
VEC02460	2014/68/UE (PED)	2000	42	1100	200	770	1970	2490	2"	2"	2"	1/2"	1/2"	2"	2"	1460
VEC02461	2014/68/UE (PED)	3000	42	1200	140	830	2250	2990	2"	2"	2"	1/2"	1/2"	2"	2"	1950
VEC02462	2014/68/UE (PED)	4000	42	1450	225	800	2145	2790	2"	3"	3"	3/4"	3/8"	3"	3"	2540
VEC02463	2014/68/UE (PED)	5000	42	1450	225	800	2745	3390	2"	3"	3"	3/4"	3/8"	3"	3"	2845

GALVANIZED VERTICAL VESSELS FOR PRESSURIZED WATER (AUTOCLAVE)

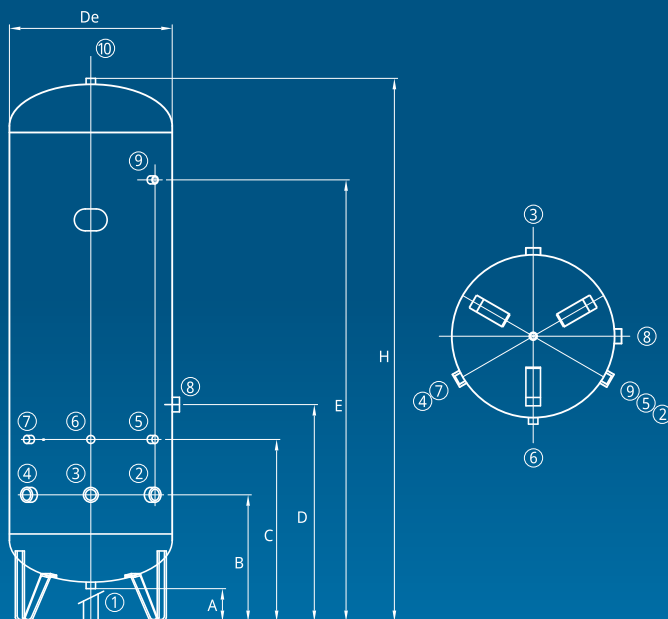

DIRECTIVE 2014/68/UE (PED)
OPERATING PRESSURE 8 BAR
OPERATING TEMPERATURE -10 +50°C

- MATERIAL: CARBON STEEL, SUITABLE FOR GALVANIZATION
- FLUID CONTENT: COMPRESSED AIR / WATER (GROUP 2)
- FINISHING: INTERNAL AND EXTERNAL HOT-DIP GALVANIZATION

CODE	Directive	Capacity	Operating Pressure	De	A	B	C	D	E	H	1	2-3-4	5-6-7	8	9	10	Weight
GALVANIZED		Lt	Bar	mm	mm	mm	mm	mm	mm	mm	inch	inch	inch	inch	inch	inch	Kg
VEC01254	2014/68/UE (PED)	100	8	370	85	345	515	615	815	1145	2"	1"	1/2"	1"1/4	1/2"	2"	34
VEC01255	2014/68/UE (PED)	100	8	396	87	328	479	579	779	1068	2"	1"	1/2"	1"1/4	1/2"	2"	35
VEC01256	2014/68/UE (PED)	200	8	446	80	360	684	784	1184	1488	2"	1"	1/2"	1"1/4	1/2"	2"	57
VEC01257	2014/68/UE (PED)	200	8	500	80	360	669	769	1160	1461	2"	1"	1/2"	1"1/4	1/2"	2"	59
VEC01258	2014/68/UE (PED)	270	8	500	130	418	783	883	1283	1632	2"	1"1/4	1/2"	1"1/4	1/2"	2"	68
VEC01259	2014/68/UE (PED)	300	8	500	130	425	856	956	1356	1782	2"	1"1/4	1/2"	1"1/4	1/2"	2"	73
VEC01260	2014/68/UE (PED)	300	8	550	130	432	732	832	1225	1530	2"	1"1/4	1/2"	1"1/4	1/2"	2"	73
VEC01261	2014/68/UE (PED)	500	8	600	120	440	944	1044	1594	1968	2"	1"1/2	1/2"	1"1/4	1/2"	2"	106
VEC01262	2014/68/UE (PED)	500	8	650	120	440	840	940	1490	1802	2"	1"1/2	1/2"	1"1/4	1/2"	2"	94
VEC01263	2014/68/UE (PED)	500	8	750	115	460	715	815	1180	1515	2"	2"	1/2"	1"1/4	1/2"	2"	93
VEC01264	2014/68/UE (PED)	750	8	750	100	500	950	1050	1700	1984	2"	2"	1/2"	1"1/4	1/2"	2"	125
VEC01265	2014/68/UE (PED)	750	8	800	110	465	865	965	1430	1820	2"	2"	1/2"	1"1/4	1/2"	2"	127
VEC01266	2014/68/UE (PED)	1000	8	800	115	525	1025	1125	1875	2319	2"	2"	1/2"	1"1/4	1/2"	2"	189

GALVANIZED HORIZONTAL VESSELS FOR PRESSURIZED WATER (AUTOCLAVE)



DIRECTIVE 2014/68/UE (PED)
OPERATING PRESSURE 8 BAR
OPERATING TEMPERATURE -10 +50°C

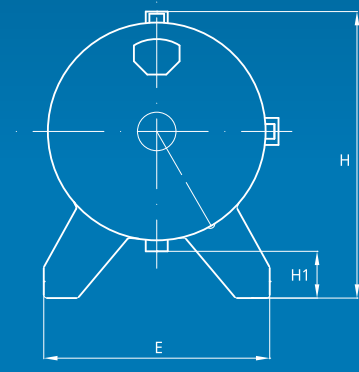
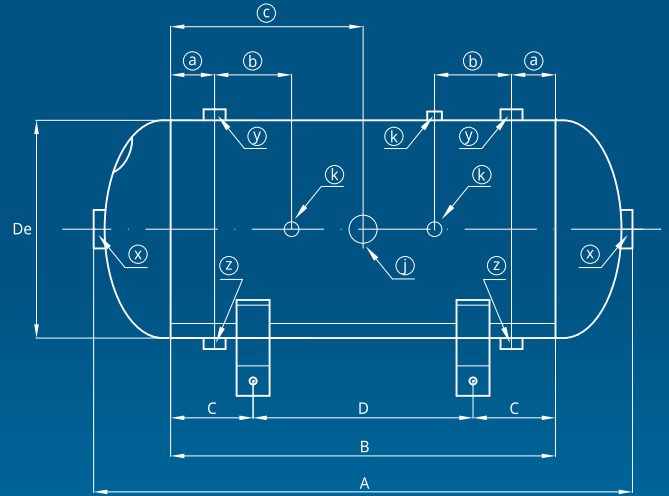
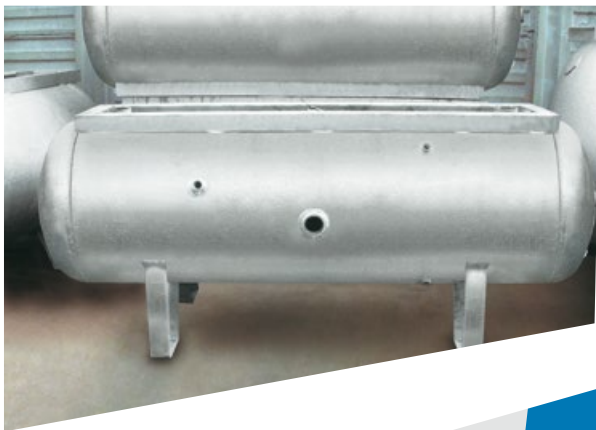

- MATERIAL: CARBON STEEL, SUITABLE FOR GALVANIZATION
- FLUID CONTENT: COMPRESSED AIR / WATER (GROUP 2)
- FINISHING: INTERNAL AND EXTERNAL HOT-DIP GALVANIZATION

CODE	Directive	Capacity	Operating Pressure	De	A	B	C	D	E	H1	H	a	b	c	x	y	z	k	j	Weight
GALVANIZED		Lt	Bar	mm	mm	mm	mm	mm	mm	mm	mm	mm	mm	mm	inch	inch	inch	inch	inch	Kg
VEC01281	2014/68/UE (PED)	100	8	396	980	700	150	400	411	85	521	80	140	350	2"	1"	1"	1/2"	1"1/4	36
VEC01282	2014/68/UE (PED)	200	8	446	1404	1100	150	800	444	83	569	80	280	550	2"	1"	1"	1/2"	1"1/4	58
VEC01283	2014/68/UE (PED)	300	8	550	1403	1000	166	668	496	144	744	90	220	500	2"	1"1/4	1"1/4	1/2"	1"1/4	74
VEC01284	2014/68/UE (PED)	500	8	600	1912	1500	240	1020	520	141	791	90	470	750	2"	1"1/2	1"1/2	1/2"	1"1/4	108
VEC01285	2014/68/UE (PED)	500	8	650	1674	1250	189	872	553	138	838	90	345	625	2"	1"1/2	1"1/2	1/2"	1"1/4	96
VEC01286	2014/68/UE (PED)	750	8	750	1890	1400	175	1050	611	151	951	90	420	700	2"	2"	2"	1/2"	1"1/4	127
VEC01287	2014/68/UE (PED)	1000	8	800	2210	1700	205	1290	641	148	999	90	570	850	2"	2"	2"	1/2"	1"1/4	191

STAINLESS STEEL VERTICAL VESSELS



- MATERIAL: AISI 304/316L STAINLESS STEEL
- FLUID CONTENT: COMPRESSED AIR / NITROGEN / COMPRESSED AIR AND WATER (GROUP 2)
- FINISHING: INTERNAL AND EXTERNAL PICKLING AND PASSIVATION
- UPON REQUEST: EXTERNAL ELECTROPOLISHING TREATMENT

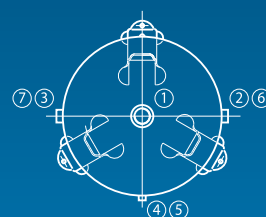
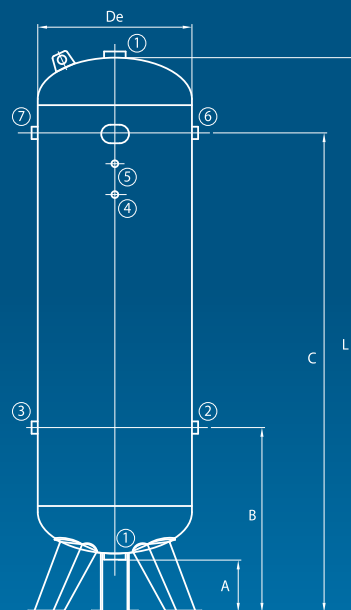

DIRECTIVE	2014/68/UE (PED)	2014/68/UE (PED)
OPERATING PRESSURE	11 BAR	11 BAR
OPERATING TEMPERATURE	*-80 +120°C	-55 +80°C

CODE	Directive	Capacity	Operating Pressure	De	A	B	C	L	1	2	3	4	5	6	7	Weight
AISI 304		Lt	Bar	mm	mm	mm	mm	mm	inch	inch	inch	inch	inch	inch	inch	Kg
VES03153	2014/68/UE(PED)	*24	11	240	40	161	553	772	1/2"	=	1/2"	=	=	1/2"	=	15
VES01881	2014/68/UE(PED)	*50	11	305	129	276	717	957	1/2"	1/2"	=	=	=	=	1/2"	21
VES01883	2014/68/UE(PED)	*100	11	370	170	358	948	1184	1/2"	=	3/4"	3/8"	3/8"	3/4"	=	32
VES03203	2014/68/UE(PED)	*150	11	446	165	400	897	1277	1/2"	1"	=	1/4"	=	=	1"	49
VES01885	2014/68/UE(PED)	*200	11	446	160	492	1192	1572	1/2"	=	1"	3/8"	3/8"	1"	=	55
VES01887	2014/68/UE(PED)	*270	11	500	165	560	1279	1771	1/2"	1"	1"	3/8"	3/8"	=	1"	69
VES01889	2014/68/UE(PED)	500	11	600	151	763	1633	2061	1/2"	1"	1"	=	3/8"	1"	1"	125
VES01891	97/23/EC (PED)	1000	11	800	140	702	1642	2346	2"	2"	2"	3/8"	3/8"	2"	2"	377
VES02812	2014/68/UE(PED)	1500	11	1000	170	680	1780	2305	2"	2"	2"	1/2"	1/2"	2"	2"	634
VES02773	2014/68/UE(PED)	2000	11	1100	170	740	1940	2460	2"	2"	2"	1/2"	1/2"	2"	2"	810
VES03787	2014/68/UE(PED)	3000	11	1200	150	878	220	2871	2"	2"	2"	1/2"	1/2"	2"	2"	942
AISI 316L		Lt	Bar	mm	mm	mm	mm	mm	inch	inch	inch	inch	inch	inch	inch	Kg
VES03155	2014/68/UE(PED)	*24	11	240	40	161	553	772	1/2"	=	1/2"	=	=	1/2"	=	15
VES01882	2014/68/UE(PED)	*50	11	305	129	276	717	957	1/2"	1/2"	=	=	=	=	1/2"	21
VES01884	2014/68/UE(PED)	*100	11	370	140	298	948	1106	1/2"	3/4"	=	3/8"	3/8"	=	3/4"	32
VES03204	2014/68/UE(PED)	*150	11	446	165	400	897	1277	1/2"	1"	=	1/4"	=	=	1"	49
VES01886	2014/68/UE(PED)	*200	11	446	160	492	1192	1572	1/2"	=	1"	3/8"	3/8"	1"	=	55
VES01888	2014/68/UE(PED)	*270	11	500	165	560	1279	1771	1/2"	1"	1"	3/8"	3/8"	=	1"	69
VES01890	2014/68/UE(PED)	500	11	600	151	763	1633	2061	1/2"	1"	1"	=	3/8"	1"	1"	125
VES01892	97/23/EC (PED)	1000	11	800	140	702	1642	2346	2"	2"	2"	3/8"	3/8"	2"	2"	377
VES02813	2014/68/UE(PED)	1500	11	1000	170	680	1780	2305	2"	2"	2"	1/2"	1/2"	2"	2"	634
VES02774	2014/68/UE(PED)	2000	11	1100	170	740	1940	2460	2"	2"	2"	1/2"	1/2"	2"	2"	810
VES03788	2014/68/UE(PED)	3000	11	1200	150	878	220	2871	2"	2"	2"	1/2"	1/2"	2"	2"	942

STAINLESS STEEL HORIZONTAL VESSELS



- MATERIAL: AISI 304/316L STAINLESS STEEL
- FLUID CONTENT: COMPRESSED AIR / NITROGEN / COMPRESSED AIR AND WATER (GROUP 2)
- FINISHING: INTERNAL AND EXTERNAL PICKLING AND PASSIVATION
- UPON REQUEST: EXTERNAL ELECTROPOLISHING TREATMENT

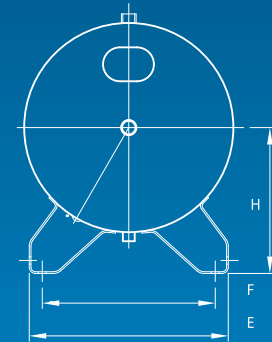
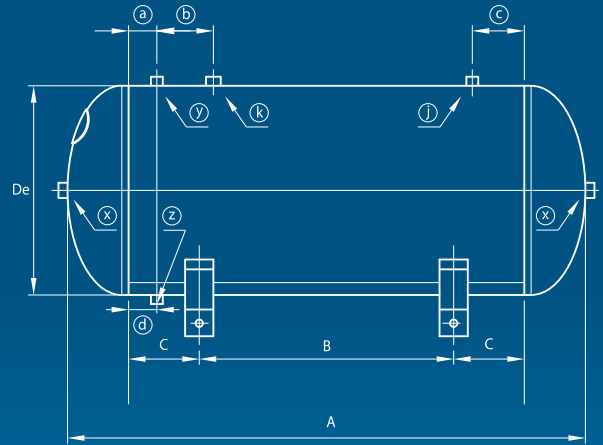

DIRECTIVE	2014/68/UE (PED)	2014/68/UE (PED)
OPERATING PRESSURE	11 BAR	11 BAR
OPERATING TEMPERATURE	*-80 +120°C	-55 +80°C

CODE	Directive	Capacity	Operating Pressure	De	A	B	C	E	F	H	a	b	c	d	x	y	k	j	z	Weight
		Lt	Bar	mm	mm	mm	mm	mm	mm	mm	mm	mm	mm	mm	inch	inch	inch	inch	inch	Kg
AISI 304																				
VES04028	2014/68/UE (PED)	*5	11	150	314	130	45	100	160	125	=	=	=	110	1/2"	=	=	=	1/2"	6
VES02586	2014/68/UE (PED)	*10	12	169	506	156	127	200	140	170	127	-	127	205	1/2"	-	1/2"	-	1/2"	8
VES02588	2014/68/UE (PED)	*15	12	196	624	156	172	200	140	178	172	-	172	250	1/2"	-	1/2"	-	1/2"	11
VES02590	2014/68/UE (PED)	*24	11	240	634	192	150	240	180	210	100	-	100	246	1/2"	-	1/2"	-	1/2"	13
VES02592	2014/68/UE (PED)	*50	11	305	784	400	100	285	236	200	100	-	100	300	1/2"	3/8"	3/8"	-	1/2"	21
VES02594	2014/68/UE (PED)	*100	11	370	966	550	100	352	306	256	45	80	45	45	1/2"	3/8"	1/2"	3/8"	3/8"	32
VES03205	2014/68/UE (PED)	*150	11	446	1064	450	175	440	386	288	50	150	50	50	1/2"	3/8"	1/2"	3/8"	1/2"	49
VES02596	2014/68/UE (PED)	*200	11	446	1364	750	175	440	386	288	50	150	50	50	1/2"	3/8"	1/2"	1/2"	3/8"	55
VES02598	2014/68/UE (PED)	*270	11	500	1558	900	175	463	409	315	50	150	120	50	1/2"	3/8"	1"	1/2"	1/2"	69
VES02600	2014/68/UE (PED)	500	11	600	1864	1204	148	530	470	396	60	155	60	60	1/2"	3/8"	1"	1/2"	1/2"	125
VES02602	2014/68/UE (PED)	1000	11	800	2200	1015	345	605	440	500	100	155	60	60	2"	3/4"	1"	1/2"	1/2"	377
AISI 316L																				
VES04026	2014/68/UE (PED)	*5	11	150	314	130	45	100	160	125	=	=	=	110	1/2"	=	=	=	1/2"	6
VES02587	2014/68/UE (PED)	*10	12	169	506	156	127	200	140	170	127	-	127	205	1/2"	-	1/2"	-	1/2"	8
VES02589	2014/68/UE (PED)	*15	12	196	624	156	172	200	140	178	172	-	172	250	1/2"	-	1/2"	-	1/2"	11
VES02591	2014/68/UE (PED)	*24	11	240	634	192	150	240	180	210	100	-	100	246	1/2"	-	1/2"	-	1/2"	13
VES02593	2014/68/UE (PED)	*50	11	305	784	400	100	285	236	200	100	-	100	300	1/2"	3/8"	3/8"	-	1/2"	21
VES02595	2014/68/UE (PED)	*100	11	370	966	550	100	352	306	256	45	80	45	45	1/2"	3/8"	1/2"	3/8"	3/8"	32
VES03206	2014/68/UE (PED)	*150	11	446	1064	450	175	440	386	288	50	150	50	50	1/2"	3/8"	1/2"	3/8"	1/2"	49
VES02597	2014/68/UE (PED)	*200	11	446	1364	750	175	440	386	288	50	150	50	50	1/2"	3/8"	1/2"	1/2"	3/8"	55
VES02599	2014/68/UE (PED)	*270	11	500	1558	900	175	463	409	315	50	150	120	50	1/2"	3/8"	1"	1/2"	1/2"	69
VES02601	2014/68/UE (PED)	500	11	600	1864	1204	148	530	470	396	60	155	60	60	1/2"	3/8"	1"	1/2"	1/2"	125
VES02603	2014/68/UE (PED)	1000	11	800	2200	1015	345	605	440	500	100	155	60	60	2"	3/4"	1"	1/2"	1/2"	377

ASME VESSELS

- MATERIAL: CARBON STEEL / STAINLESS STEEL
- FLUID CONTENT: COMPRESSED AIR / NITROGEN / ARGON / HELIUM / OIL / OXYGEN (GROUP 1 - HYDROGEN EXCLUDED)
- FINISHING: IN COMPLIANCE WITH CUSTOMER'S REQUIREMENTS OR OUR STANDARD OPTIONS (FOR MORE DETAILS SEE PAGE 5)

DIRECTIVE

**ASME SECTION VIII
DIVISION 1**

OPERATING PRESSURE

DA 145 A 300 PSI

OPERATING TEMPERATURE

-20 +250°F

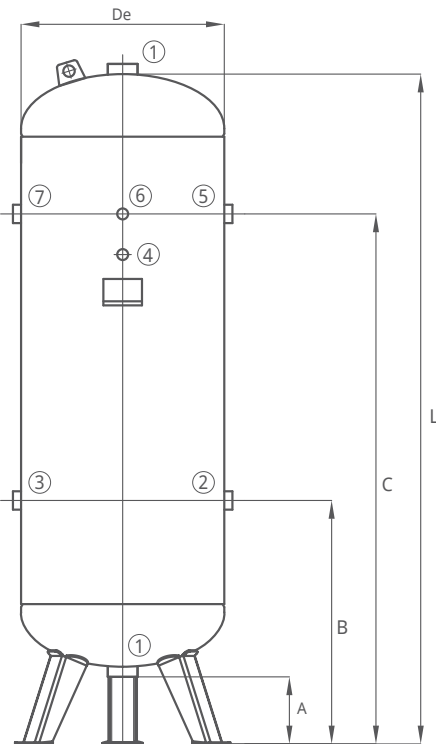
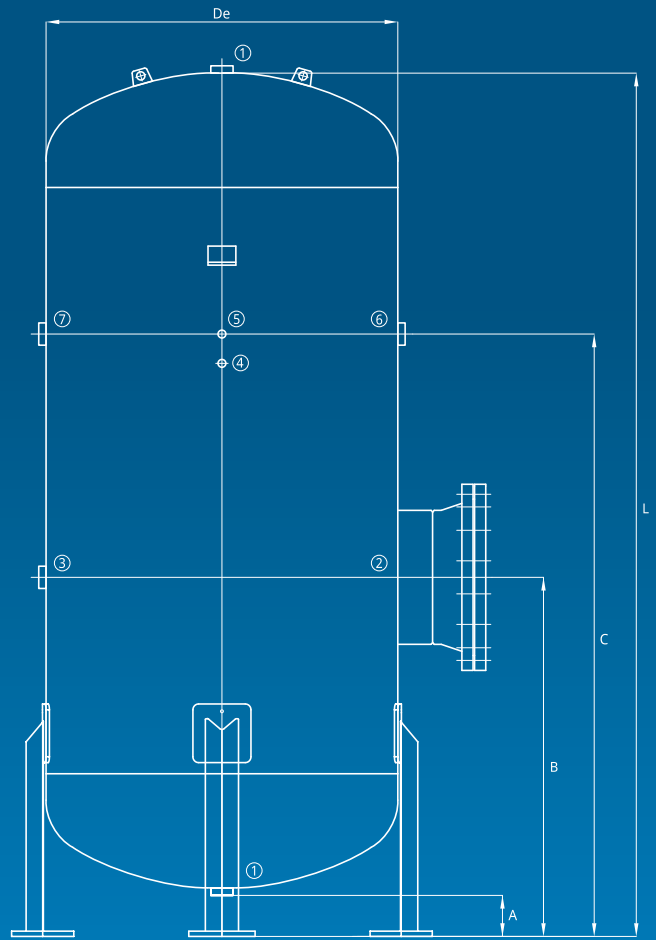

Capacity	De	A	B	C	L	1	2	3	4	5	6	7
Lt	mm	mm	mm	mm	mm	inch	inch	inch	inch	inch	inch	inch
2000	1100	200	770	1970	2490	2"	2"	2"	1/2"	1/2"	2"	2"
3000	1200	140	830	2250	2990	2"	2"	2"	1/2"	1/2"	2"	2"
5000	1450	225	900	2745	3390	2"	3"	3"	3/4"	3/8"	3"	3"

Capacity	De	A	B	C	L	1	2	3	4	5	6	7
Lt	mm	mm	mm	mm	mm	inch	inch	inch	inch	inch	inch	inch
270	500	175	599	1304	1648	2"	1"	1"	-	3/8"	1"	1"
500	600	155	785	1665	2050	2"	2"	2"	1/2"	1/2"	2"	2"
1000	800	145	770	1720	2350	2"	2"	2"	3/8"	3/8"	2"	2"

FLANGED CONNECTIONS AND NON-MANDATORY INSPECTION OPENINGS

The following table is valid only for vessels with operating temperature not less than -20°C and pressure of 11 and 16 bar. (from pag. 14 to pag.18)







Volume	Pressure (Bar)	DN40	DN50	DN65	DN80	DN90	DN100	DN125	DN150	DN200	DN250	Handhole 100x150 mm	Manhole 300x400 mm
1000	12	•	•	•	•	•	•	•	•	•		•	
1000	16	•	•	•	•	•	•	•	•	•		•	
1500	12	•	•	•	•	•	•	•	•	•		•	•
1500	16	•	•	•	•	•	•	•	•	•		•	•
2000	12	•	•	•	•	•	•	•	•	•		•	•
2000	16	•	•	•	•	•	•	•	•	•		•	•
3000	12	•	•	•	•	•	•	•	•	•	•	•	•
3000	16	•	•	•	•	•	•	•	•	•	•	•	•
4000	12	•	•	•	•	•	•	•	•	•	•	•	•
4000	16	•	•	•	•	•	•	•	•	•	•	•	•
5000	8	•	•	•	•	•	•	•	•	•	•	•	•
5000	12	•	•	•	•	•	•	•	•	•	•	•	•
5000	16	•	•	•	•	•	•	•	•	•	•	•	•
6000	12	•	•	•	•	•	•	•	•	•	•	•	•
6000	16	•	•	•	•	•	•	•	•	•	•	•	•
8000	8	•	•	•	•	•	•	•	•	•	•	•	•
8000	12	•	•	•	•	•	•	•	•	•	•	•	•
8000	16	•	•	•	•	•	•	•	•	•	•	•	•
10000	8	•	•	•	•	•	•	•	•	•	•	•	•
10000	12	•	•	•	•	•	•	•	•	•	•	•	•
10000	16	•	•	•	•	•	•	•	•	•	•	•	•

Declaration of conformity

All pressure vessels for the European market are supplied with a declaration of conformity bearing all vessel identification data.

This certificate shall be duly kept to be submitted to inspection authorities during periodical audits as specified by the applicable regulations.

FOR INQUIRIES CONCERNING DECLARATION OF CONFORMITY PLEASE CONTACT
quality@baglionispa.com

CE

DICHIARAZIONE DI CONFORMITÀ

DECLARATION DE CONFORMITE DECLARACIÓN DE CONFORMIDAD

DECLARATION OF CONFORMITY KONFORMITÄTSEKLRÄRUNG

• Dichiariamo, sotto la nostra responsabilità, che il serbatoio nuovo qui descritto:

Nous déclarons, sous notre seule responsabilité, que le récipient neuf décrit ci après:

We hereby declare under our own responsibility, that the pressure vessel described hereunder:

Declaramos, bajo nuestra unica responsabilidad, que el recipiente nuevo descrito aqui:

Unter unserer Verantwortung erklären wir hiermit, daß der neue unten beschriebene Druckluftbehälter:

N.F.:	Capacità:	LOTTO N.:	Anno di fabbricazione:
N.F.:	Volume:	LOT N.:	Année de fabrication:
Manufacturing N.:	Capacity:	Lot inspection:	Year of construction:
Matricula N.:	Capacidad:	Lote N.:	Año de fabricación:
Bau-Nr.:	Inhalt:	Losprüfung:	Baujahr:
De 9491 A 9526	Lt. 500	03/09	2009
Famiglia:	Pressione di servizio/Calcolo:	Variante:	Temperatura di servizio:
Famille:	Pression de service/Calcul:	Variante:	Temperature de service:
Family:	Operating pressure/Calculation:	Type:	Operating temperature:
Familia:	Presión de servicio/Calculo:	Variación:	Temperatura de servicio:
Familie:	Betriebsüberdruck/Berechnungsdru:	Typ:	Betriebstemperatur:
EC	bar 16	EC500.16	-10°C +120°C

È CONFORME ALLE DISPOSIZIONI DELLA DIRETTIVA CEE 87/404 RELATIVA AI RECIPIENTI SEMPLICI A PRESSIONE

EST CONFORME AUX DISPOSITIONS DE LA DIRECTIVE 87/404 CEE RELATIVE AUX RECIPIENTS A PRESSION SIMPLES

COMPLIES WITH ECC DIRECTIVE 87/404 CONCERNING SIMPLE PRESSURE VESSELS

ES CONFORME A LAS DISPOSICIONES DE LA NORMATIVA CEE 87/404 RELATIVA A LOS RECIPIENTES A PRESION SIMPLES

DEN VORSCHRIFTEN EG-RICHTLINIE 87/404 ÜBER EINFACHE DRUCKBEHÄLTER ENTSPRICHT

• che il modello della famiglia e sue varianti alla quale questo serbatoio appartiene è stata riconosciuta una:

que le modèle de la famille et ses variantes à laquelle appartient ce récipient a fait l'objet de la délivrance d'une:

that the family type and its variations, which this vessel is part of, has received:

que el modelo de la familia y sus tipos al que pertenece este recipiente ha sido el objeto de la deliberación de una:

daß der betreffende Behältertyp mit:

ATTESTAZIONE D'ESAME DEL TIPO N° 07.72226/C/PS DEL 18/10/07 REV. 18/10/07 rilasciata da CPM, organismo notificato n°I-0398

ATTESTATION D'EXAMEN CE DE TYPE N° 07.72226/C/PS DU 18/10/07 M.J. 18/10/07 délivrée par la CPM, organisme notifié n°I-0398

ECC TYPE EXAMINATION CERTIFICATE N° 07.72226/C/PS DATED 18/10/07 REV. 18/10/07 issued by CPM, official test body n°I-0398

CERTIFICACION DE EXAMEN CE DE TIPO N° 07.72226/C/PS DEL 18/10/07 REV. 18/10/07 expedido por CPM, organismo notificado n°I-0398

EG-BAUMUSTERPRÜFUNG NR. 07.72226/C/PS VOM 18/10/07 REV. 18/10/07 von anerkannter Prüfstelle CPM, n°I-0398 geprüft wurde

• che questo serbatoio ha superato una prova idraulica a una Pressione di Prova uguale a 1,5 volte la pressione di calcolo.

que ce récipient a subi avec succès un essai hydraulique à une Pression d'Epreuve égale à 1,5 fois la Pression de calcul.

that the aforementioned pressure vessel passed the hydraulic test when submitted to a test pressure equal to 1,5 times the design pressure.

que este recipiente ha superado con seguridad una prueba hidráulica a una presión igual a 1,5 veces la presión de cálculo.

daß obiger Behälter die Wasserdruckprobe bestanden hat, wobei der Proberdruck 1,5 mal der Nenndruck entsprach.

• che l'Organismo notificato ha apposto una punzonatura di identificazione (cuore APAVE) sulla targa del costruttore.

que l'Organisme notifié a apposé un poinçon identification (coeur APAVE) sur la plaque constructeur.

that the notified institution has applied a marking punch on the name plate.

que el Organismo notificado ha puesto una marca de identificación (corazon APAVE) sobre la placa constructor.

daß die anerkannte Prüfstelle einen Kennzeichnungsstempel auf das Herstellerschild gestempelt hat.

Terruggia, il 2/7/2009

Il Costruttore – Le Constructeur – The Manufacturer
 El constructor – Der Hersteller

CSC099491-9526



Pagina 1 di 2

EXHIBIT ONLY - NOT USABLE

INSTRUCTIONS FOR USE AND MAINTENANCE

Instructions for a proper use and maintenance of the vessels are found on page 2 of the Dec. of conf. A strict attention of these instructions will ensure the lifespan and safe use of the vessels. The parameters displayed at the bottom of this sheet are of the utmost importance to this purpose:

- Rating (A): refers to design pressure (bar) as well as the pressure limit for vessel use. This rate is found both on the name plate and the Declaration of Conformity
- Rating (B): refers to shell thickness (mm) below which the vessel can no longer be kept in operation
- Rating (C): refers to formed heads thickness (mm) below which the vessel can no longer be kept in operation

It is extremely important that ratings (B) and (C) are tested regularly because water, gas or bacterial reactions may cause natural corrosion phenomena which will determine the deterioration of materials and eventually jeopardize the product's performance.

NOTICES D'INSTRUCTION

Le récipient à pression est destiné à l'accumulation d'air comprimé et ne doit pas être soumis à de rapides fluctuations de pression. L'utilisation adéquate de l'appareil à air comprimé est une condition préalable essentielle pour en garantir la sécurité. Dans ce but l'utilisateur doit:

- 1) employer l'appareil de façon appropriée dans les **limites établies de pression et de température** de service qui sont indiquées sur la plaque du Constructeur.
- 2) éviter d'effectuer des soudures sur les parties à pression;
- 3) vérifier que l'appareil soit équipé d'**organes de sécurité (soupape de sécurité et pressostat) et de contrôle (manomètre)** efficaces et suffisants et veiller à leur remplacement, en cas de nécessité, par d'autres organes ayant des caractéristiques équivalentes, après en avoir informé le Constructeur. En particulier, la soupape de sécurité doit être appliquée directement sur le réservoir sans possibilité d'interposition, doit avoir une capacité de décharge supérieure à la quantité d'air qui peut être admise dans le réservoir, être tarée et plombée à la pression de (A) bar. Sur le manomètre, l'index de pression de (A) bar doit être indiqué par un trait rouge.
- 4) éviter autant que possible de placer l'appareil dans des locaux qui ne sont pas suffisamment aérés; éviter scrupuleusement d'installer l'appareil dans des zones exposées à des sources de chaleur ou à proximité de substances inflammables.
- 5) équiper impérativement l'appareil de liaisons élastiques sur les supports inférieurs et quelque soit le modèle (fixe ou mobile) pendant son utilisation de façon à éviter des vibrations qui pourraient provoquer des ruptures par fatigues. Ne pas fixer le récipient ou des parties montées sur le récipient au sol ou sur des parties fixes (colonnes, ...).
- 6) **Prevenir la corrosion:** selon le mode d'emploi, des condensats peuvent s'accumuler dans les réservoirs, ceux-ci doivent être purgés tous les jours. Cela peut se faire manuellement en ouvrant la purge de condensat ou par un purgeur automatique monté sur le réservoir. Dans le cadre de la maintenance l'utilisateur, ou le service après-vente habilité, doit vérifier la formation éventuelle de corrosion à l'intérieur et effectuer un contrôle extérieur à intervalles annuels. Si le récipient est utilisé avec un compresseur sec, dans un environnement humide, ou dans des conditions défavorables (faible ventilation, vapeur acide ...) le contrôle visuel doit se faire plus fréquemment. **L'épaisseur effective du réservoir après corrosion ne devra pas être inférieure à (B) mm pour la virole et (C) mm pour les fonds.**
- 7) agir en tout cas avec bon sens et pondération de manière analogue aux cas prévus.

TOUTE MANIPULATION ET UTILISATION IMPROPRE DE L'APPAREIL SONT FORMELLEMENT INTERDITES.

Rappel à l'utilisateur que dans tous les cas, il est tenu de respecter la législation sur l'utilisation des appareils à pression du Pays ou il en fait usage.

INSTRUCTION FOR USE OF COMPRESSED AIR VESSEL

The pressure vessel is intended to be used for storage of compressed air and shall not be subject to rapid fluctuation of pressure. To ensure operation of compressed air vessel under safe conditions, the proper use of same must be guaranteed.

To this purpose, the user should proceed as follows:

- 1) use the vessel properly, **within the pressure and temperature limits** stated on the nameplate and on the testing report, which must be kept with care;
- 2) welding on the vessel is forbidden;
- 3) assure that the vessel is complete with suitable and adequate **safety and control fittings** and replace them with equivalent ones in case of necessity, prior to the Manufacturer's consent. In particular, the safety valve must be applied directly to the vessel, have a discharge capacity higher than the air intake and be set and leaded at a pressure of (A) bar. The pressure value of (A) bar on the pressure gauge should be indicated with a red mark;
- 4) avoid, if it is possible, to store the vessel in **badly ventilated rooms**. Avoid scrupulously to store the vessel near heating sources or inflammable substances;
- 5) fit the pressure vessel with **vibration dampers** to avoid possible fatigue failure caused by vibration of the vessel during use. Don't anchor the vessel or attached components to the ground or fixed structures (columns etc.).
- 6) **Corrosion must be prevented:** depending on the conditions of use, condensation may accumulate inside the tank, and this must be emptied out every day. This may be done manually, by opening the draining tap, or by means of the automatic condensation drainer, if fitted to the tank. During maintenance, every 12 months, the user or a Client Service expert must check the presence of **internal corrosion** and perform an external visual control. If the receiver is used with an oil-free compressor, or in surroundings that have a high level of humidity, or in adverse conditions (poor ventilation, corrosive agents, ...), the inspections should be made more frequently. **The actual wall thickness of the tank after corrosion should not be smaller than (B) mm for the shell and (C) mm for the heads**. The legal checks have to be made in accordance with the local laws and rules where the receiver is used.
- 7) proceed sensibly and carefully, according to the existing prescriptions.

TAMPERING AND IMPROPER USE OF THE TANK ARE FORBIDDEN

The users must comply with the laws on the operation of pressure equipment in force in the relative countries.

BETRIEBSANWEISUNGEN

Der Behälter ist bestimmt zur Speicherung von Druckluft; seine Auslegung erfolgte für überragend statischen Betrieb. Die korrekte Bedienung des Druckluftbehälters ist eine unabdingbare Voraussetzung, um die Sicherheit zu gewährleisten. Zu diesem Zweck sollte der Anwender wie folgt vorgehen:

- 1) den Druckluftbehälter innerhalb der **Nenn-Druck- und Temperaturgrenzen** verwenden, die auf dem Schild und in der Konformitätserklärung angegeben sind, die mit der größten Sorgfalt zu bewahren ist;
- 2) keine Schweißungen auf drucktragenden Teilen durchführen;
- 3) sich vergewissern, dass der Behälter mit dem entsprechenden **Sicherheits- und Prüfzubehör** ausgestattet ist, das in Notfall durch gleichwertige Ausrüstung nach Rücksprache mit dem Hersteller zu ersetzen ist. Insbesondere muss die Sicherheitsventile unmittelbar auf den Behälter angebracht werden, eine höhere Abblaskapazität als der Luftzufuhr haben und auf einen Druck von (A) bar geeicht und plombiert werden. Auf dem Druckmesser muss der Druckwert von (A) bar in Rot gekennzeichnet sein;
- 4) möglichst vermeiden, dass der Druckluftbehälter in **schlecht belüfteten Räumen** aufgestellt wird; sorgfältig vermeiden, dass der Behälter **Wärmequellen oder entflammaren Stoffen** ausgesetzt wird;
- 5) der Behälter ist mit Vibrationsdämpfern auszustatten, um zu vermeiden, dass er während des Betriebs Vibrationen ausgesetzt wird, die Dauerbrüche verursachen können; der Behälter oder an ihm montierte Teile dürfen nicht am Boden oder an feststehenden Teilen (Pfeilen, ...) befestigt werden;
- 6) **Vorbeugung gegen Korrosion:** Je nach Betriebsbedingungen können sich im Behälter Kondensat ansammeln, das täglich abgelassen werden muss. Dies kann entweder manuell durch Öffnen des Abblaskventiles oder durch einen eingebauten automatischen Kondensatabläßer erfolgen. Im Rahmen der Wartung muß der Behälter einer regelmäßigen, jährlichen Kontrolle auf interne **Korrosion** durch den Betreiber oder den zuständigen Kundendienst und einer ausser Sichtprüfungen unterzogen werden. Beim Betrieb des Behälters mit einem ölfreien Kompressor bei hoher Luftfeuchtigkeit oder ungünstigen Betriebsbedingungen (wenig Frischluft, Säuredämpfe o.ä.) sollte die Sichtprüfung in geringeren Zeitabständen erfolgen. **Die tatsächliche Wandstärke des korrodierten Behälters darf auf keinen Fall (B) mm am Mantel und (C) mm an den Böden unterschreiten.** Die gesetzlich vorgeschriebenen Prüfungen müssen gemäß der geltenden Gesetze des Landes organisiert werden, in dem der Behälter verwendet wird.
- 7) bei der Montage und Inbetriebnahme des Behälters prüfen, ob Betriebsvorschriften eingehalten sind.

MUTWILLIGE BESCHÄDIGUNGEN UND MIßBRAUCH DES BEHÄLTERS SIND VERBOTEN.

Die Anwender werden darauf hingewiesen, die im jeweiligen Land gültigen Gesetzesvorschriften über den Betrieb der Druckbehälter zu befolgen.

ISTRUZIONI D'USO

Il serbatoio a pressione è destinato all'accumulo di aria compressa ed è calcolato per utilizzo principalmente statico. Un suo corretto utilizzo è premessa indispensabile per garantirne la sicurezza.

A tale scopo l'utilizzatore deve ma non solo:

- 1) utilizzare correttamente il serbatoio nei **limiti di pressione e di temperatura** di progetto che sono riportati sulla targua del Costruttore e sulla dichiarazione di conformità che deve essere conservata con cura;
- 2) evitare di effettuare saldature sulle parti esposte a pressione;
- 3) garantire che il serbatoio sia sempre completo di efficienti e sufficienti accessori di sicurezza e di controllo e provvedere in caso di necessità alla loro sostituzione con altri di equivalenti caratteristiche, sentito in merito il Costruttore. In particolare, la valvola di sicurezza deve essere applicata direttamente sul recipiente senza possibilità di interposizione, deve avere una capacità di scarico superiore alla quantità di aria che può essere immessa nel recipiente, essere tarata e plombata alla pressione di (A) bar. Sul manometro, l'indice di pressione di (A) bar deve essere indicato con un segno rosso;
- 4) evitare se possibile di utilizzare il serbatoio in locali non sufficientemente aerati; evitare scrupolosamente di collocare il serbatoio in zone esposte a sorgenti di calore o nelle vicinanze di sostanze infiammabili;
- 5) munire il serbatoio di anti-vibranti in modo da evitare che il serbatoio durante l'esercizio sia soggetto a vibrazioni che possono generare rotture per fatica, non bloccare al suolo o a parti fisse (colonne, ...) il serbatoio o parti ad esso montate;
- 6) **Prevenire la corrosione:** a seconda delle condizioni d'impiego, può accumularsi all'interno del serbatoio della condensa che deve essere scaricata quotidianamente. Ciò può essere fatto manualmente aprendo il rubinetto di scarico o attraverso lo scaricatore di condensa automatico se montato sul serbatoio. Nell'ambito della manutenzione, annualmente l'utilizzatore o un esperto del servizio assistenza deve verificare l'insorgere di eventuali **corrosione interna** nel serbatoio ed effettuare un controllo visuale esterno. Se il recipiente è utilizzato con compressore olioso o in ambienti che presentano un alto tasso di umidità o condizioni di inumidità sfavorevoli (scarca ventilazione, agenti corrosivi, ...) i controlli devono essere eseguiti ad intervalli più ravvicinati. **Lo spessore effettivo del recipiente dopo corrosione non dovrà essere inferiore a mm. (B) per il mantello e mm (C) per i fondi;** i controlli legalmente richiesti devono essere organizzati secondo le leggi e le norme del Paese dove il serbatoio è utilizzato.
- 7) Agire in ogni caso con senno e ponderazione in analogia ai casi previsti.

E' TASSATIVAMENTE VIETATA LA MANOMISSIONE DEL SERBATOIO E OGNI UTILIZZAZIONE IMPROPRIA.

Il serbatoio a P x V maggiore uguale a 0.000 bar x l fino a pressione maggiore di 12 bar sono soggetti alle verifiche di primo impianto e alle visite periodiche di parte dell'ente preposto così come definito nel D.M. 209 del 01.12.2004

INSTRUCCIONES PARA EL USO

El depósito de aire comprimido sirve para acumular el aire comprimido y no debe someterse a rápidas variaciones de presión. La condición indispensable para garantizar la seguridad es la utilización correcta del depósito a presión de aire comprimido. Para ello el usuario deberá observar las siguientes reglas:

- 1) utilizar de forma correcta el depósito teniendo en cuenta los **límites de presión y temperatura** para los que ha sido diseñado, valores que aparecen indicados en la placa del Constructor y en el documento de conformidad que debe ser cuidadosamente guardado;
- 2) no efectuar soldaduras en las piezas a presión;
- 3) cercionarse de que el depósito siempre vaya provisto de eficientes y suficientes **accesorios de seguridad y control** y en caso necesario substituirlos con otros de características equivalentes, tras conformidad del Constructor. En concreto, la válvula de seguridad debe ser aplicada directamente en el recipiente sin posibilidad de interposición, debe tener una capacidad de descarga superior a la cantidad de aire que puede ser introducida y ponderación en analogía a los casos previstos;
- 4) si es posible, no colocar el depósito en locales no **suficientemente ventilados** - no colocar nunca el depósito en **zonas expuestas a fuentes de calor o cerca de sustancias inflamables**;
- 5) instalar antivibraciones en el depósito para evitar que durante su uso esté sujeto a vibraciones que puedan provocar roturas por desgaste; no fijar el depósito ni piezas que tenga montadas al suelo ni a elementos fijos (columnas, etc.);
- 6) **Prevenir la corrosión:** dependiendo de las condiciones de uso, en el interior del depósito puede acumularse condensación que debe descargarse diariamente. Esta operación debe realizarse manualmente abriendo la llave de descarga o a través del descargador automático de condensación instalado en el depósito. Referente a la mantención, el usuario o un técnico del servicio debe comprobar anualmente si hay formación de **corrosiones en el interior del depósito e inspeccionar el exterior**. Si el recipiente se utiliza con compresores en seco o en lugares con un alto índice de humedad, o en condiciones de uso desfavorables (poca ventilación, agentes corrosivos, ...) los controles deberán realizarse con mayor frecuencia. **De todas formas el espesor efectivo del recipiente tras la corrosión no deberá ser inferior a los (B) mm en la capa cilíndrica y los (C) mm en el fondo;** los controles exigidos legalmente deberán llevarse a cabo de acuerdo con las leyes y normas vigentes en el país donde se utilice el depósito.
- 7) actuar siempre con racionalidad y ponderación teniendo en cuenta los casos previstos.

ESTA TAXATIVAMENTE PROHIBIDA LA MANIPOLACION DEL DEPÓSITO Y TODA UTILIZACION INADECUADA.

Se recuerda que el usuario debe respetar las leyes de utilización de los depósitos a presión vigentes en el país en el que se utilizan.

(A) = 16 (B) = 4,45 (C) = 4,05

famiglia EC N.F. dal 9491 al 9526

Pagina 2 di 2

EXHIBIT ONLY - NOT USABLE

MINIMUM HEADS THICKNESS

MINIMUM SHELL THICKNESS (CYLINDER BODY)

DESIGN PRESSURE

ACCESSORIES

CODE	Unit	Description	Material	Directive	Calibration	Drain flow rate
KIT00024	1	Safety valve with G 1/2" connection	BRASS	2014/68/UE (PED)	11 Bar	7237
	1	Ø 63 mm G 1/4" pressure gauge			11 Bar	Lt/min
KIT00100	1	Safety valve with G 3/4" connection	BRASS	2014/68/UE (PED)	11 Bar	17767
	1	Ø 63 mm G 1/4" pressure gauge			11 Bar	Lt/min
KIT00093	1	Safety valve with G 1" connection	BRASS	2014/68/UE (PED)	11 Bar	38221
	1	Ø 63 mm G 1/4" pressure gauge			11 Bar	Lt/min
KIT00026	1	Safety valve with G 3/4" connection	BRASS	2014/68/UE (PED)	12 Bar	19184
	1	Ø 63 mm G 1/4" pressure gauge			12 Bar	Lt/min
KIT00028	1	Safety valve with G 1" connection	BRASS	2014/68/UE (PED)	12 Bar	41407
	1	Ø 63 mm G 1/4" pressure gauge			12 Bar	Lt/min
KIT00114	1	Safety valve with G 1/2" connection	BRASS	2014/68/UE (PED)	15 Bar	9650
	1	Ø 63 mm G 1/4" pressure gauge			15 Bar	Lt/min
KIT00031	1	Safety valve with G 1/2" connection	BRASS	2014/68/UE (PED)	16 Bar	10253
	1	Ø 63 mm G 1/4" pressure gauge			16 Bar	Lt/min
KIT00088	1	Safety valve with G 3/4" connection	BRASS	2014/68/UE (PED)	16 Bar	24851
	1	Ø 63 mm G 1/4" pressure gauge			16 Bar	Lt/min
KIT00023	1	Safety valve with G 1" connection	BRASS	2014/68/UE (PED)	16 Bar	54147
	1	Ø 63 mm G 1/4" pressure gauge			16 Bar	Lt/min
KIT00040	1	Safety valve with G 1/2" connection	BRASS	2014/68/UE (PED)	21 Bar	16517
	1	Ø 63 mm G 1/4" pressure gauge			25 Bar	Lt/min
KIT00105	1	Safety valve with G 1/2" connection	BRASS	2014/68/UE (PED)	32 Bar	24811
	1	Ø 63 mm G 1/4" pressure gauge			32 Bar	Lt/min
KIT00106	1	Safety valve with G 1" connection	BRASS	2014/68/UE (PED)	32 Bar	103110
	1	Ø 63 mm G 1/4" pressure gauge			32 Bar	Lt/min
KIT00107	1	Safety valve with G 1/2" connection	BRASS	2014/68/UE (PED)	42 Bar	32350
	1	Ø 63 mm G 1/4" pressure gauge			42 Bar	Lt/min
KIT00087	1	Safety valve with G 1" connection	BRASS	2014/68/UE (PED)	42 Bar	134442
	1	Ø 63 mm G 1/4" pressure gauge			42 Bar	Lt/min
KIT00030	1	Safety valve with G 1/2" connection	BRASS	2014/68/UE (PED)	8 Bar	5419
	1	Ø 63 mm G 1/4" pressure gauge			8 Bar	Lt/min
KIT00102	1	Safety valve with G 1" connection	BRASS	2014/68/UE (PED)	8 Bar	28666
	1	Ø 63 mm G 1/4" pressure gauge			8 Bar	Lt/min
KIT00044	1	Safety valve with G 1/2" connection	STAINLESS STEEL 316L	2014/68/UE (PED)	11 Bar	8983
	1	Ø 63 mm G 1/4" pressure gauge			11 Bar	Lt/min
KIT00103	1	Safety valve with G 1" connection	STAINLESS STEEL 316L	2014/68/UE (PED)	11 Bar	37317
	1	Ø 63 mm G 1/4" pressure gauge			11 Bar	Lt/min
ART00122	1	Pressure gauge flange with G 3/8" connection	BRASS	-	-	-



PRESSURE GAUGE
Ø 63 mm G 1/4"



PRESSURE GAUGE
FLANGE
G 3/8"



BALL TAP
1/2" - G 1"



SAFETY VALVE
WITH G 1/2"
CONNECTION



SAFETY VALVE
WITH G 1"
CONNECTION



SAFETY VALVE
WITH G 3/4"
CONNECTION



SAFETY VALVE
WITH G 1/2"
CONNECTION



SAFETY VALVE
WITH G 1"
CONNECTION

SPECIAL PROJECTS

We closely cooperate with our customers during activities of research and development, supporting their quality and specification requirements with a view to ideal product integration in the system where our vessels are to be installed.

We ensure the utmost care and attention to customized design projects in accordance with customer specifications and instructions, e.g., special flange mounting requirements, manual welding or customized carpentries.





COMPRESSED GAS s.r.o., www.kompresory-servis.sk info@boge.sk



www.baglionspa.com

Baglioni SpA | Via Dante Alighieri, 8
28060 San Pietro Mosezzo | Novara | ITALY
PHONE:+39 0321 485211 - **FAX:**+39 0321 53571